

User's Manual

GARUDAN[®]

MN-4500 Series



ANITA B s.r.o.

Průmyslová 2453/7

680 01 Boskovice

Czech Republic

tel: +420 516 454 774

+420 516 453 496

fax: +420 516 452 751

e-mail: info@anita.cz

www.garudan.cz

All rights reserved

All rights reserved property of Anita B and protected by copyright. The use of this content without written permission is prohibited. Copyright © Anita B s r.o. (2016)

General Safety Instructions

Warning ! When using this machine , basic safety precautions should always be followed to reduce the risk of fire , electric shock and personal injury .

Read all these instructions before operating this product and save these instructions.

1.Keep work area clean.

Cluttered areas and benches invite injuries.

2.Consider work area environment.

Do not expose power to rain. Do not use machine tools in damp or wet locations. Keep work area well lit. Do not use power tools where there is risk to cause fire or explosion.

3.Guard against electric shock.

Avoid body contact with earthed or grounded surfaces (e.g. pipes , radiators , refrigerators)

4.Keep children away.

Do not let visitors touch the tool or extension cord.

5.Dress properly.

Do not wear loose clothing or jewelry, they can be caught in moving parts. Wear protecting hair covering to contain long hair.

6.Do not abuse the cord.

Never carry the machine by cord or yank it to disconnect it from the socket. Keep the cord away from heat, oil and sharp edges.

7.Maintain machine with care.

Follow instructions for lubrication and changing accessories. Inspect tool cord periodically and if damaged , have it repaired by an authorized serviced facility.

8.Disconnect machine power

When not in use, before servicing and changing accessories , please disconnect electricity.

9.Avoid unintentional starting.

Do not carry plugged - in tool with finger on the switch. Ensure switch is off when plugging in.

10.Check damaged parts.

Before further use of the machine , after replaced the damaged parts , the machine should be carefully checked to determine that it will operate properly and perform its intended function.

11.Warning

The use of any accessory or attachment, other than those recommended in this instruction manual, may present a risk of personal injury.

12.Have your machine repaired by a qualified person.

Repairs should only be carried out by qualified persons and using original spare parts.

Special Warning For Electric Connection !

1.Incorporate this machine only with "CE" certificate switch.

2.Follow the instruction manual to install control device.

3.Always earth machine appropriately during operation.

4.Before adjustment, parts change or servicing must be sure to pull out the plug from socket to prevent the hazard of unintentionally start of machine.

3.HOW TO INSTALL THE MACHINE

3-1

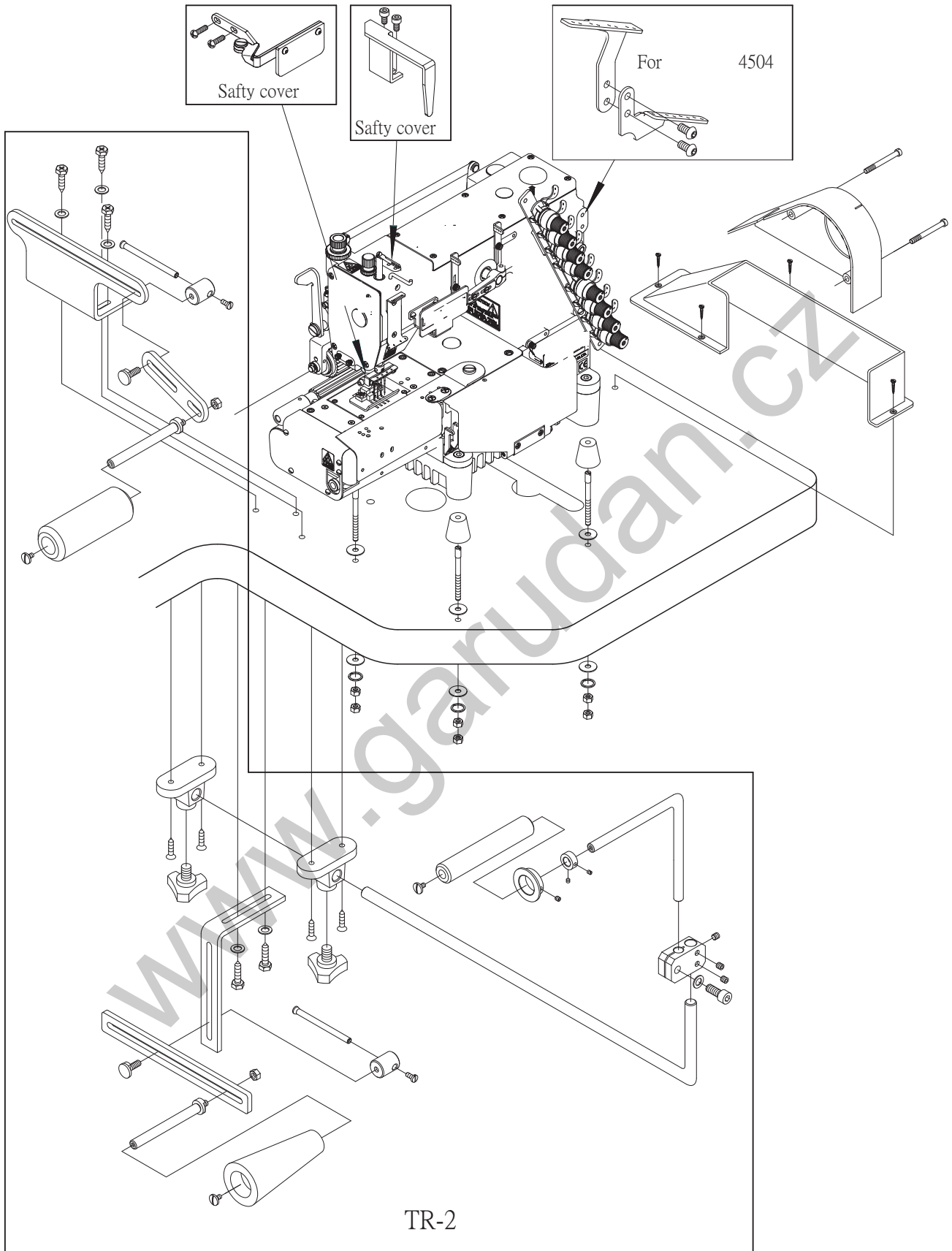

TR-2 Fabric Tension Controlling Device For (4504P)

3-2 How to install the tension stand of 4506 / -4509 / -4512
-4513 / -4517 / -4523

3-2-1

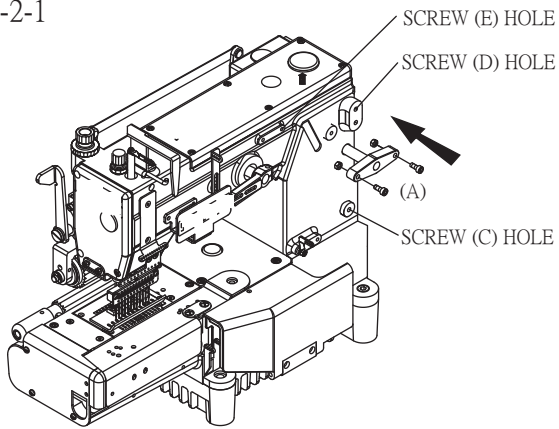

PLEASE TAKE OUT THE DRIVING STUD(A) FROM DRIVING.

3-2-5

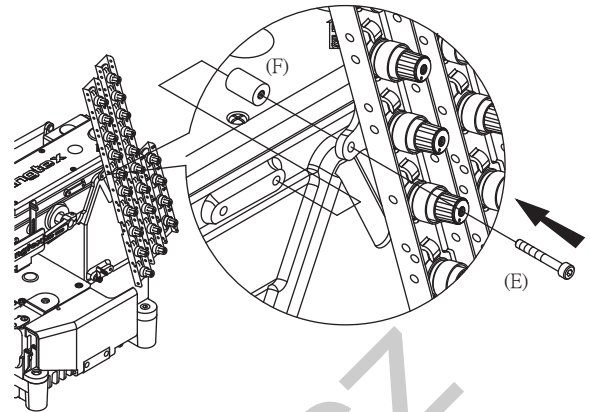

TIGHTEN THE SCREW (E) AND SCREW (F)

3-2-2

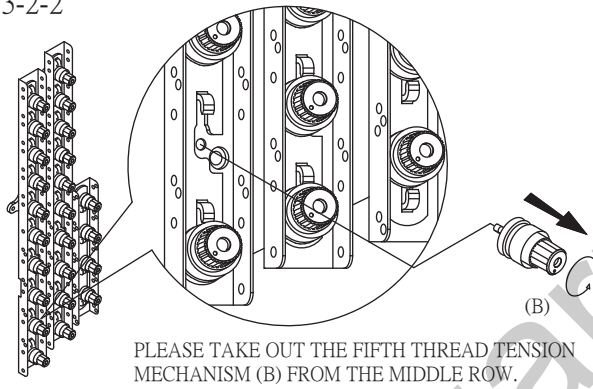

PLEASE TAKE OUT THE FIFTH THREAD TENSION MECHANISM (B) FROM THE MIDDLE ROW.

3-2-6

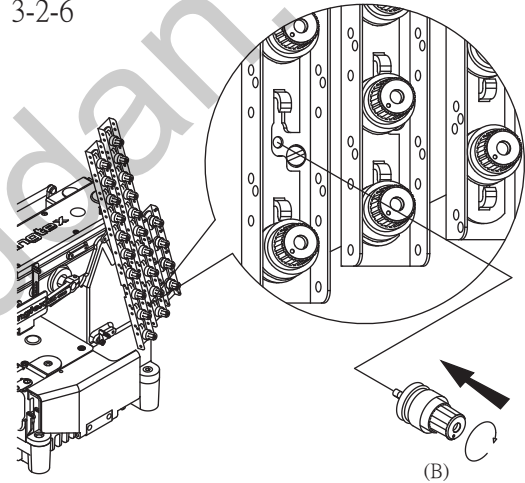

TIGHTEN UP THE TENSION NUT (B)

3-2-3

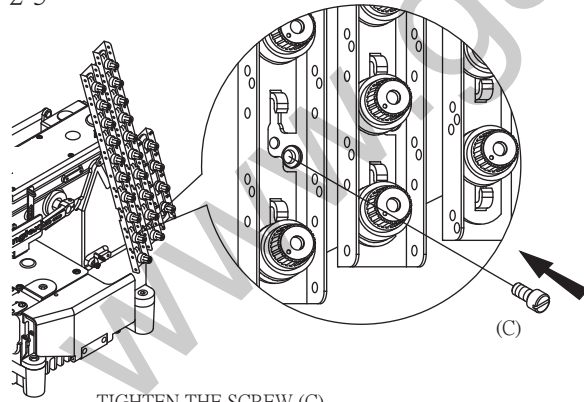

TIGHTEN THE SCREW (C)

3-2-4

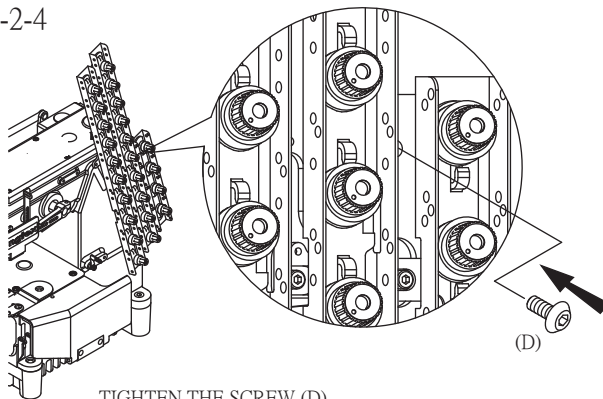

TIGHTEN THE SCREW (D)

4. BEFORE OPERATION

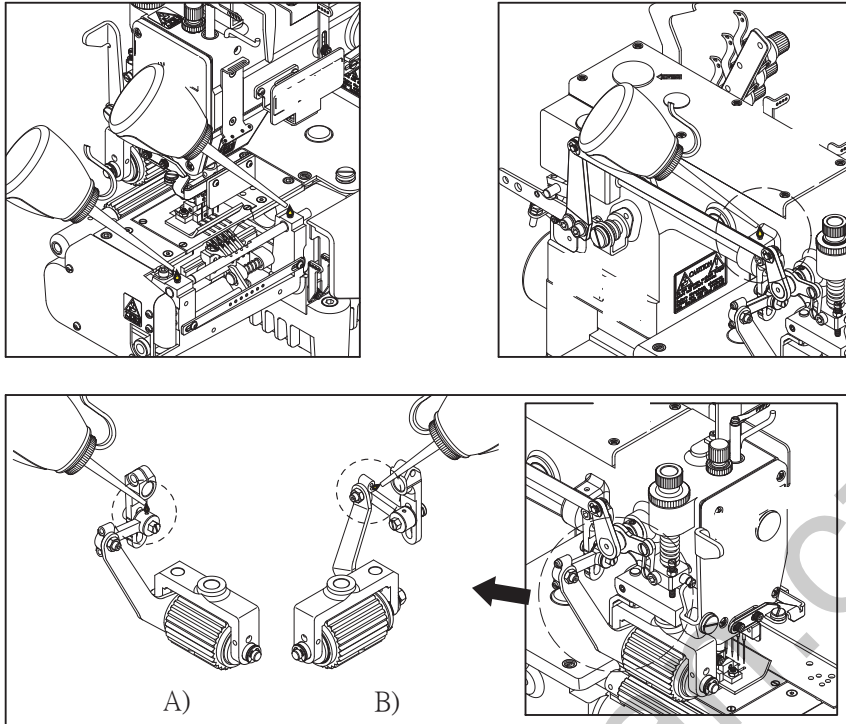

⚠ Apply two or three drops of oil to the needle bar guide and upper looper guide when operating the machine for the first time after setup or after a long period of disuse.

5. NEEDLES

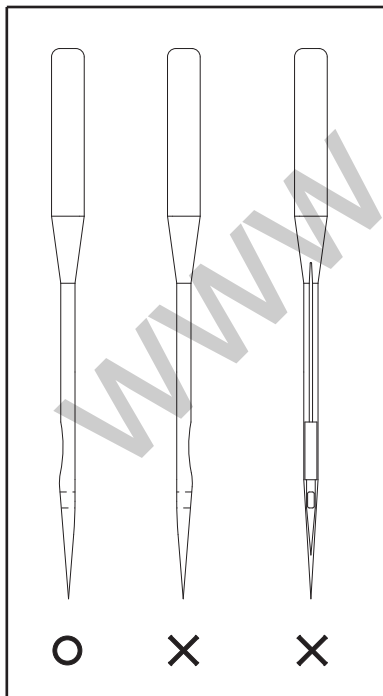

<Note>

Be sure to turn off the machine power before replacing the needle. The clutch motor continues running for a while after the machine is turned off. Therefore keep on pressing the pedal until the machine stops completely.

Needles :

UO × 113 of Schmetz or Organ

Select the proper needle for the fabric and thread to be used.

<Needle count comparison table>

Schmetz DV × 57	Nm 75	Nm 80	Nm 90	Nm 100
Organ DV × 57	#11	#12	#14	#16

Replacing the needle

When replacing the needle, check the needle carefully to see if the scarf is turned to the left (see the illustration).

6.CAUTION IN SETTING UP MOTOR BELT

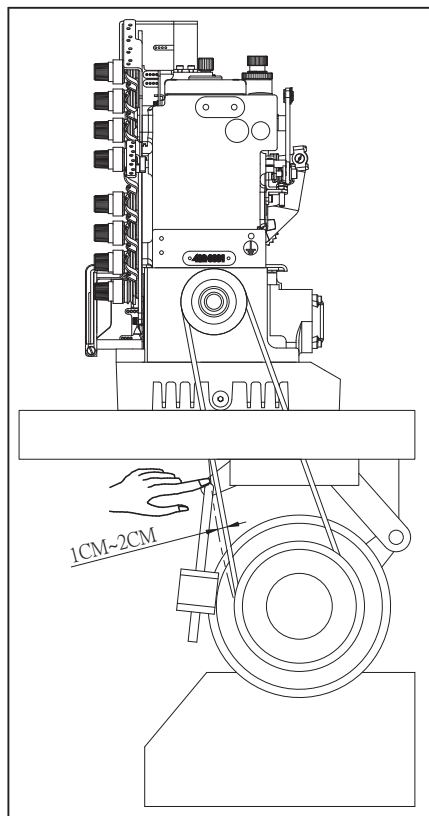

△ A.BELT: M type V belt and be sure that the motor turning direction is clockwise and the motor belt tension can be pressed inward about 2 cm.

< Machine speed >

Model	Maximum speed	Standard speed
4504P	4500	4000
4004P		
4512P	4000	3500
4012P		

< Motor pulley selection table >

Motor pulley out diameter (mm)	Machine speed (SPM)	
	50Hz	60Hz
60	3150	2950
70	2300	3450
80	3300	3900
90	3700	4400
100	4100	(4900)
110	4500	(5400)

7.LUBRICATION

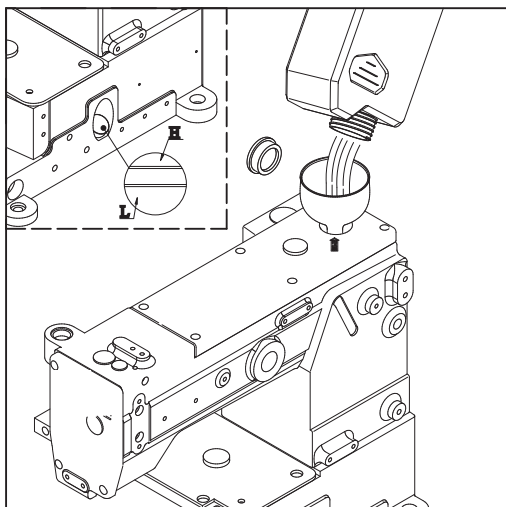

- 1.Remove oil cap.
- 2.Pour shell oil telus C-100.
- 3.Always keep the red indicator within the two red lines.

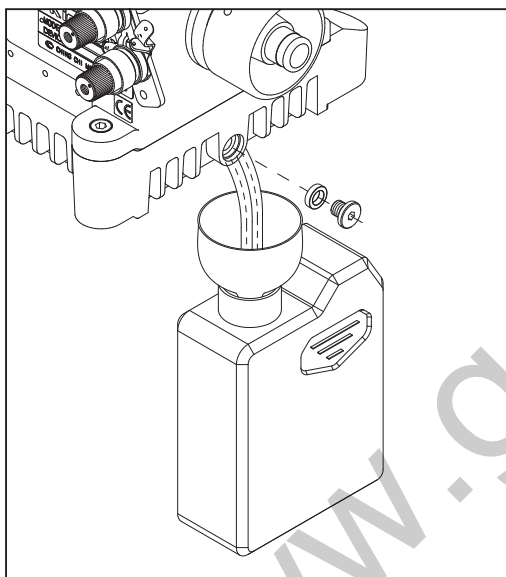

△ Please renew the lubrication oil after the first month usage, then renew it again every 4 months thereafter.

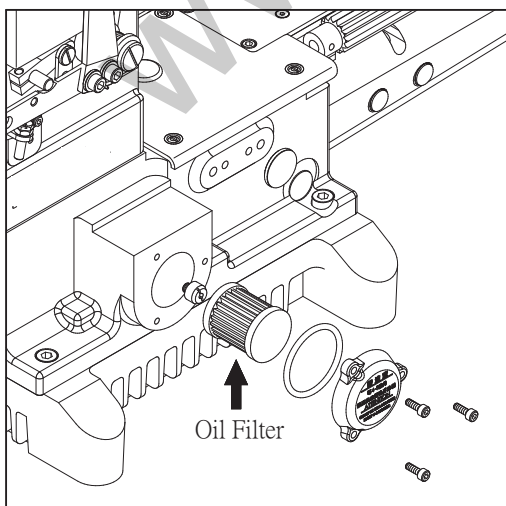

△ The filter should be cleaned once a month, and renew it if necessary.

8.ASSEMBLING THE TENSION STAND OF 4500/ 4500

△1-needle , 4-needle , 6-needle , 9-needle and 12-needle machine has a separate type of tension stand. Assemble each stand correctly by referring to the illustration.

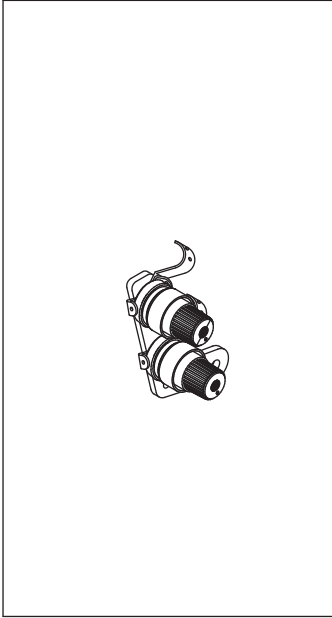

For 1-needle machine

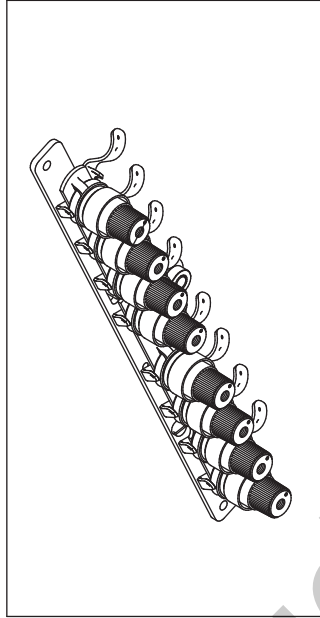

For 4-needle machine

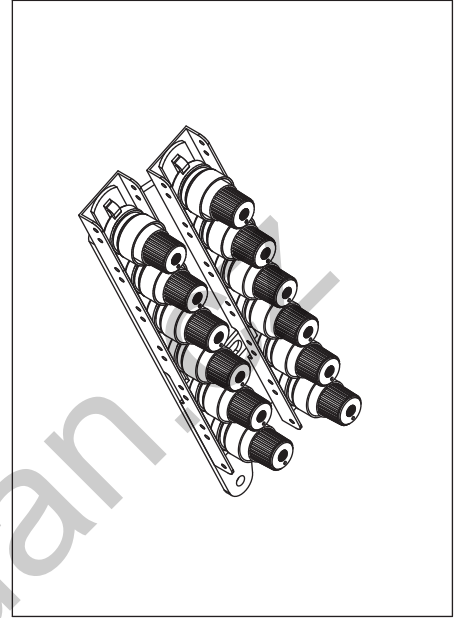

For 6-needle machine

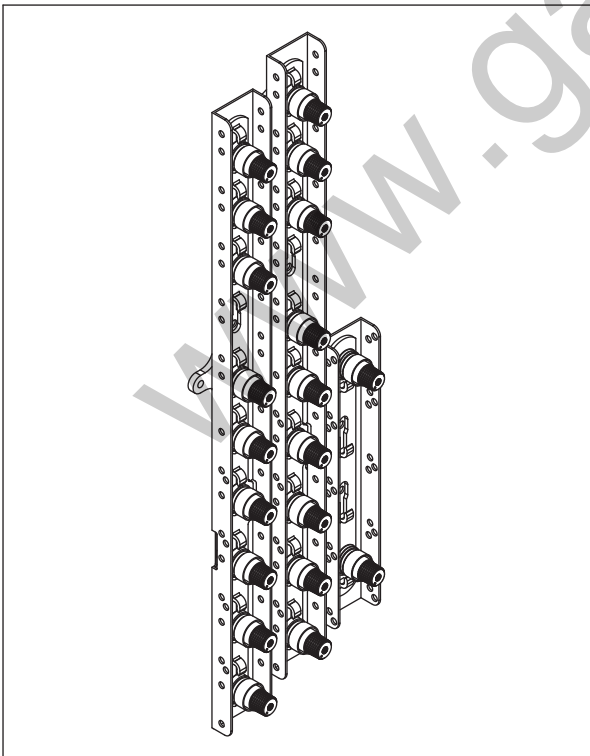

For 9-needle machine

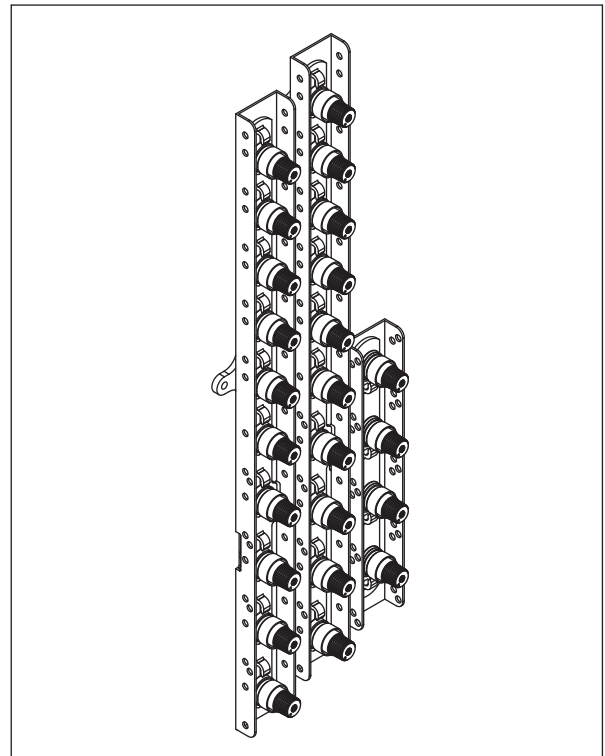

For 12-needle machine

9.ASSEMBLING THE TENSION STAND OF 4000

△1-needle , 4-needle , 6-needle , 9-needle and 12-needle machine has a separate type of tension stand. Assemble each stand correctly by referring to the illustration.

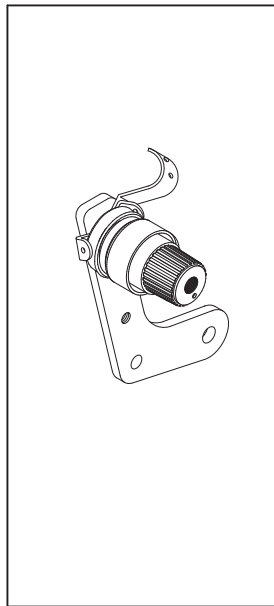

For 1-needle machine

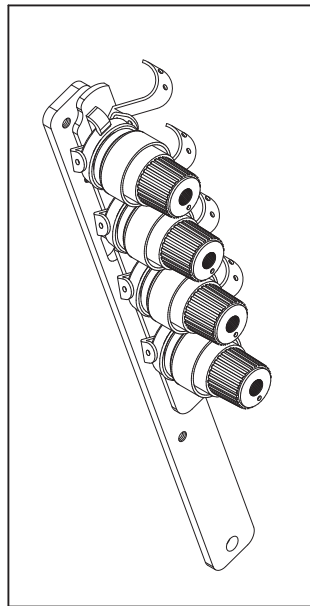

For 4-needle machine

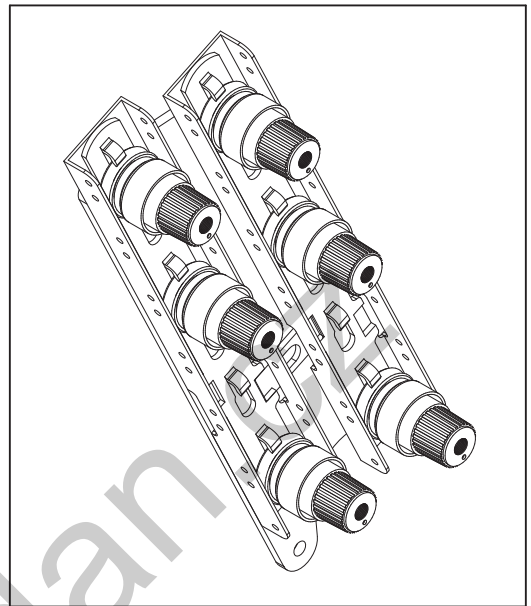

For 6-needle machine

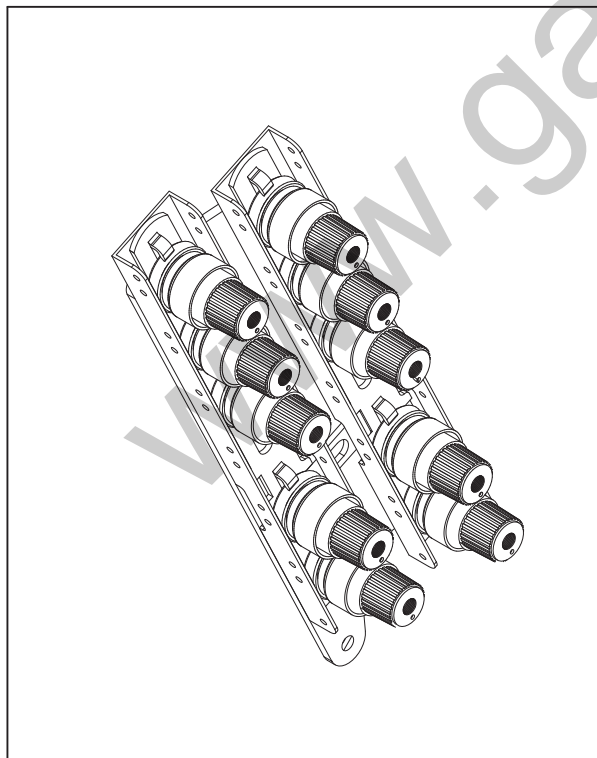

For 9-needle machine

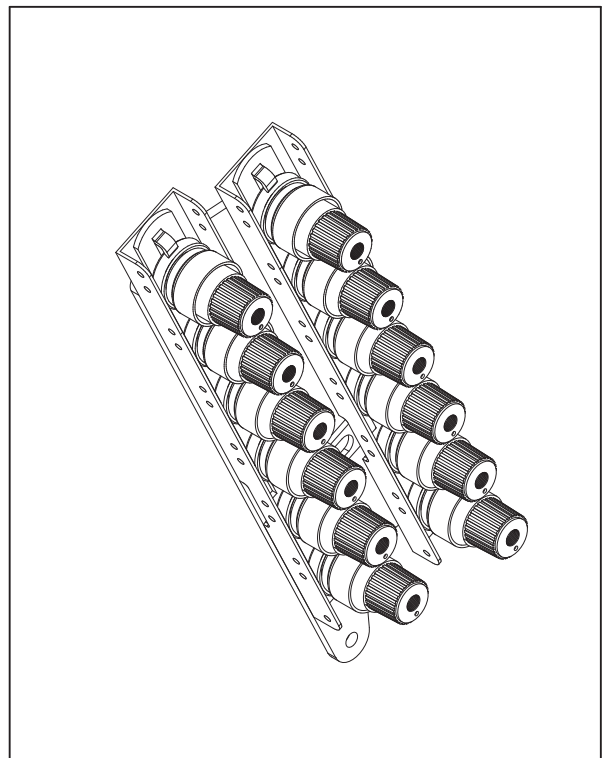

For 12-needle machine

10.THREADING THE MACHINE

Incorrect threading may cause skip stitching, thread breakage and/or uneven stitch formation. When threading the looper, holder toward the front of the machine and using the looper drawing bar.

To tilt the looper toward the front

- 1.Bring needle bar A to the top of its stroke.
- 2.Pay out the needle thread from the spool by pressing the finger down on needle threads B.
- 3.Pull looper drawing bar knob C out to the left so that the looper holder is tilted toward the front of machine.
- 4.After the machine were threaded, replace the looper by pushing looper holder D back into the machine until it clicks.

<Note>

The looper pops out of the machine as soon as knob C is pulled, so do not bring your fingers close to the looper.

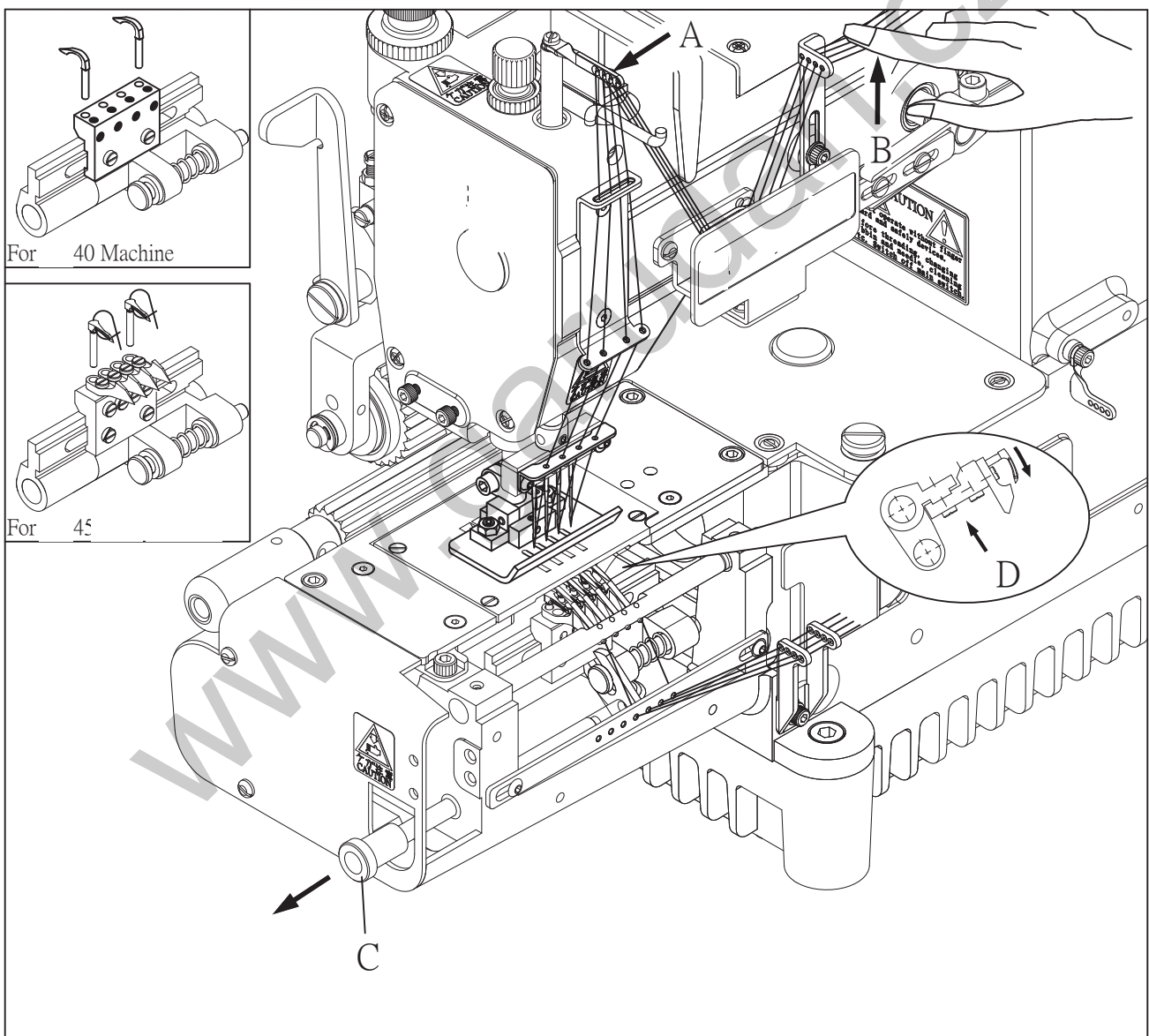

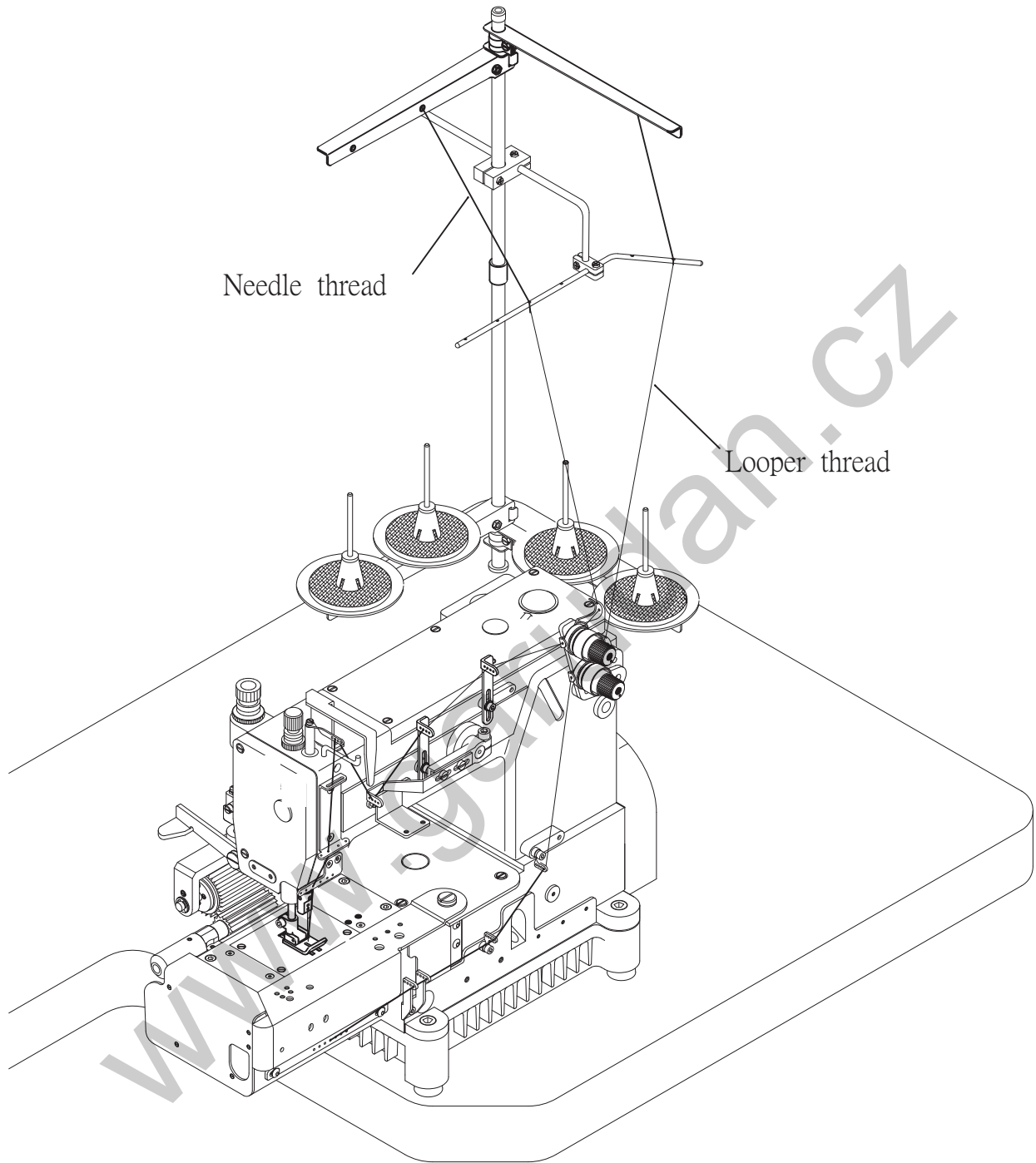

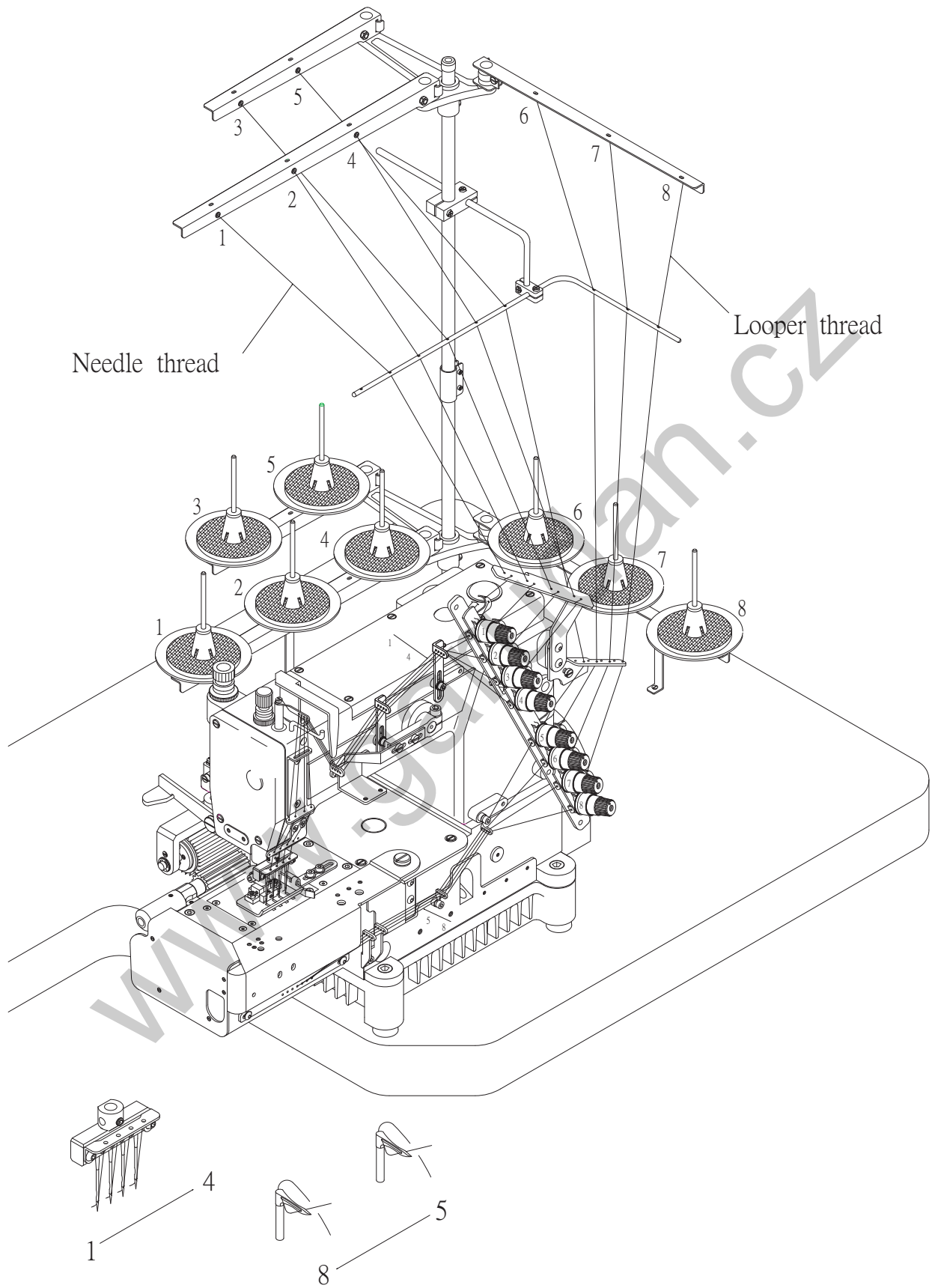

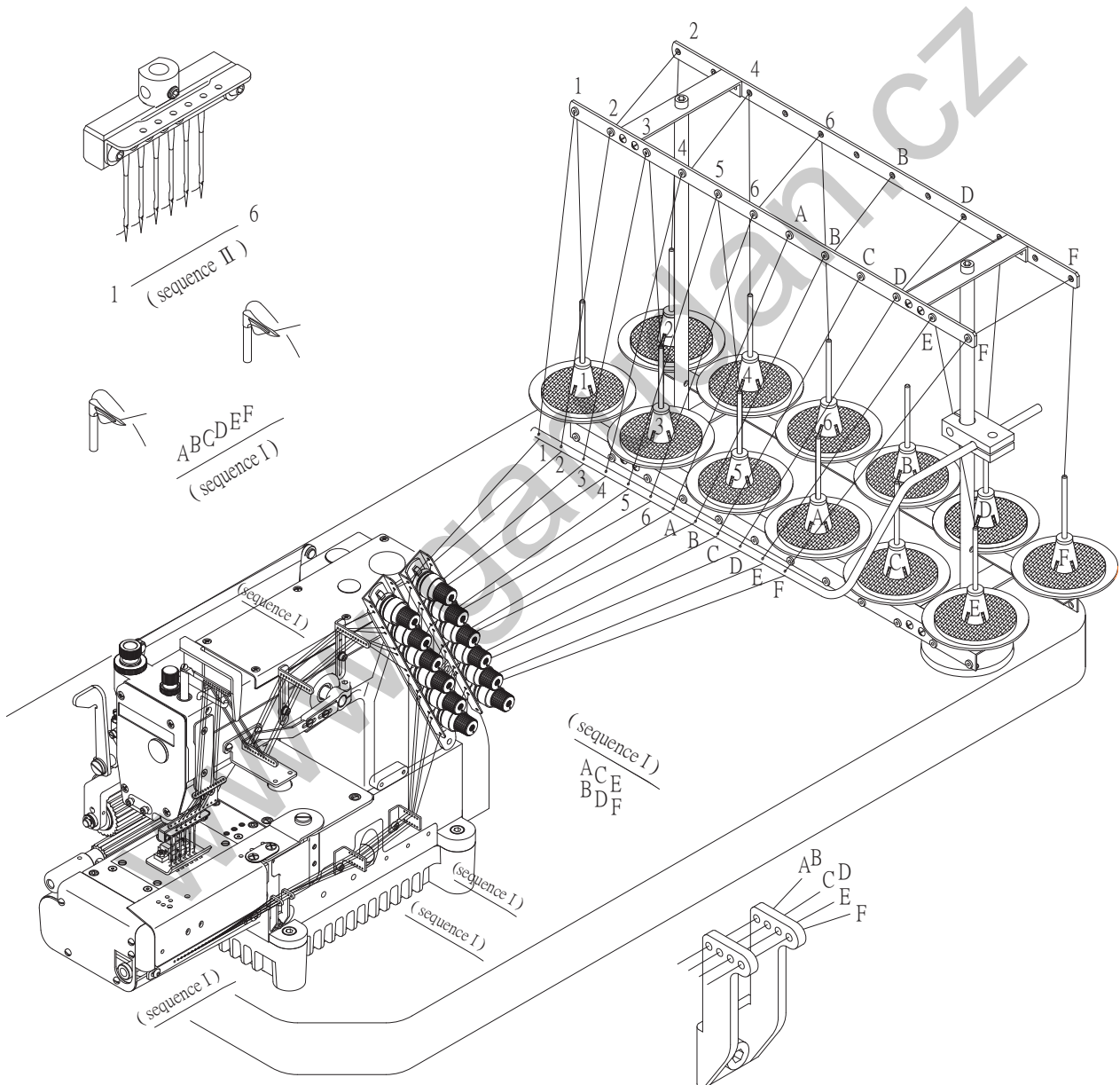
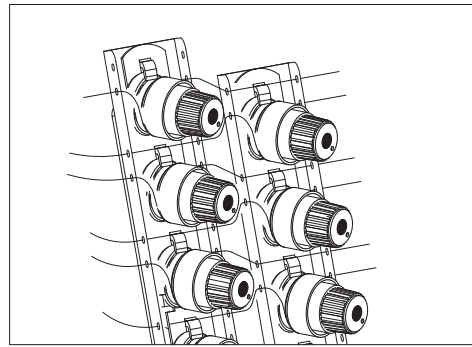

A , B : Thru one hole ; C , D : Thru one hole
 E : Thru one hole ; F : Thru one hole
 As drawing above

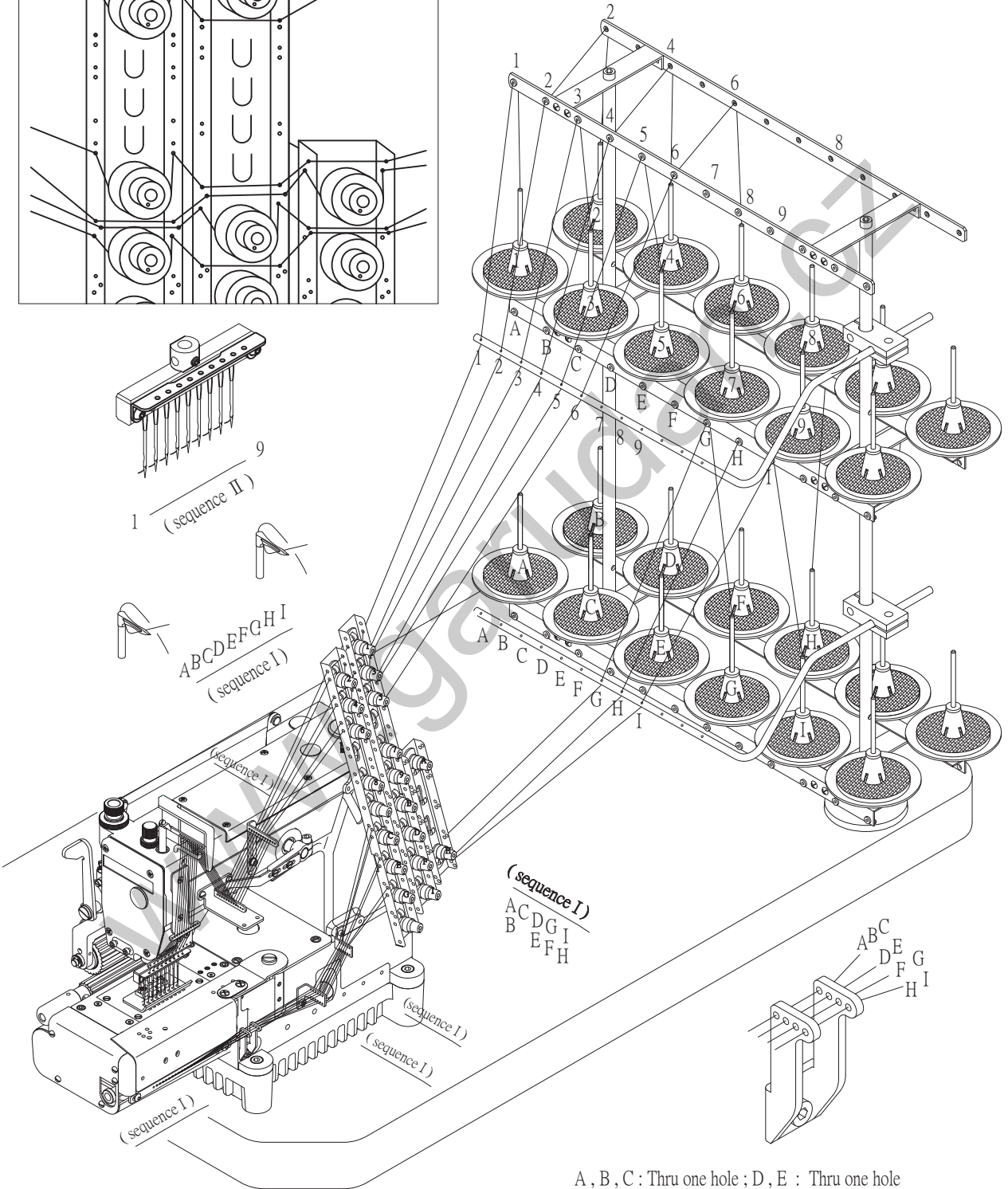
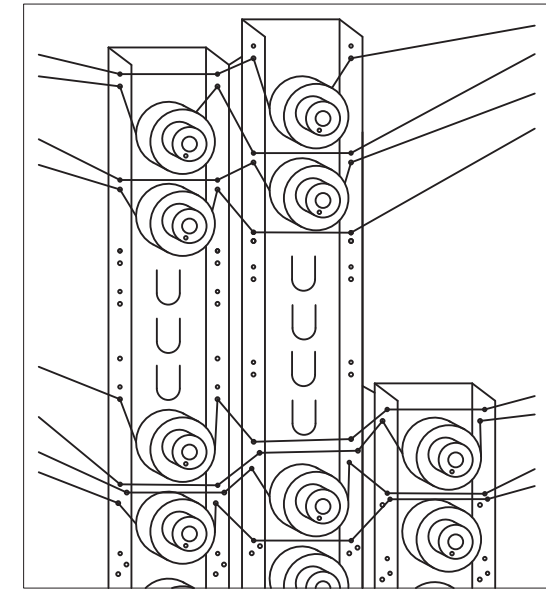

A , B , C : Thru one hole ; D , E : Thru one hole
 F , G : Thru one hole ; I , H : Thru one hole
 As drawing above

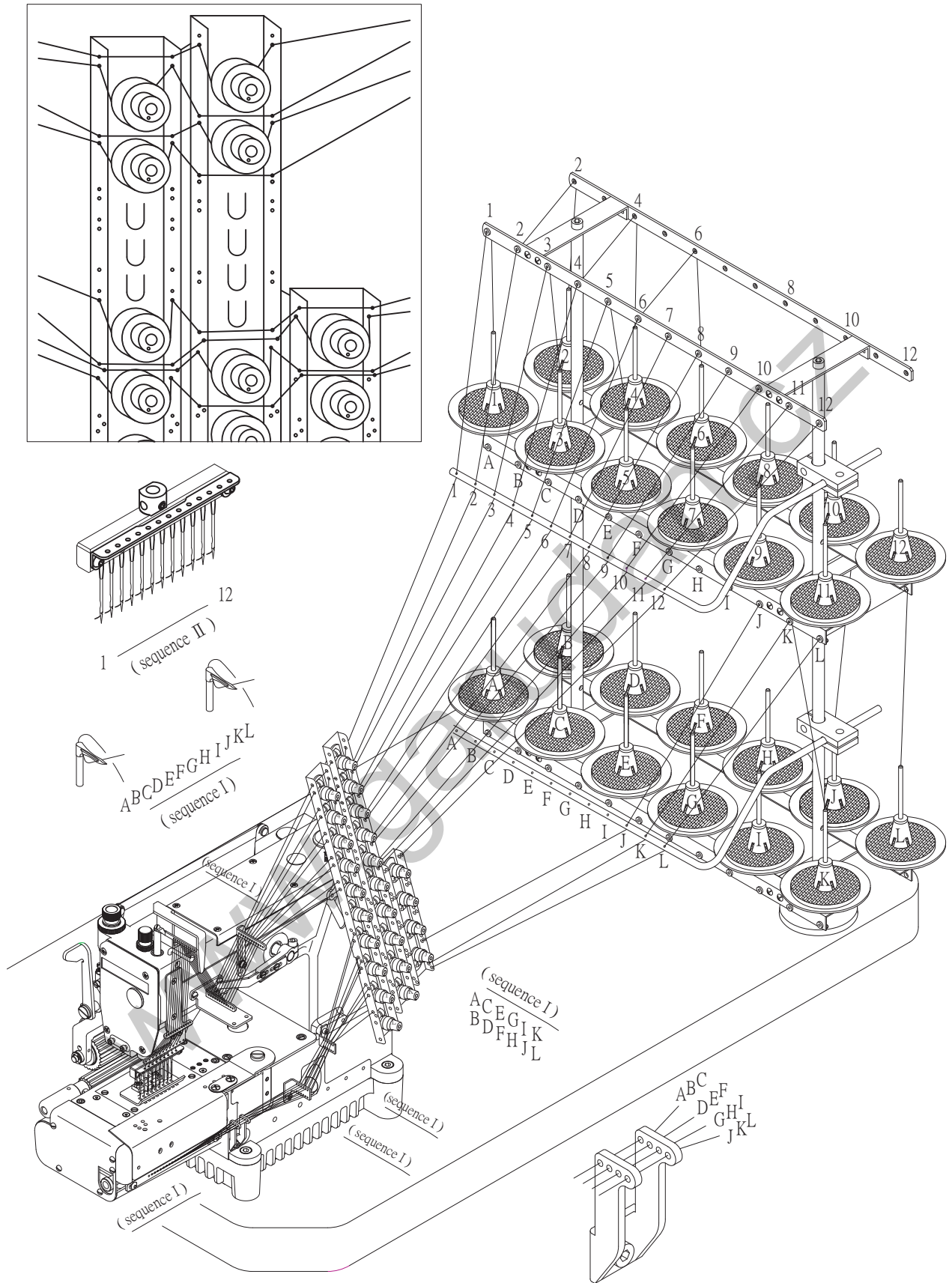

A , B , C : Thru one hole ; D , E , F : Thru one hole
 G , H , I : Thru one hole ; J , K , L : Thru one hole
 As drawing above

16.THREADING DIAGRAM FOR 4001

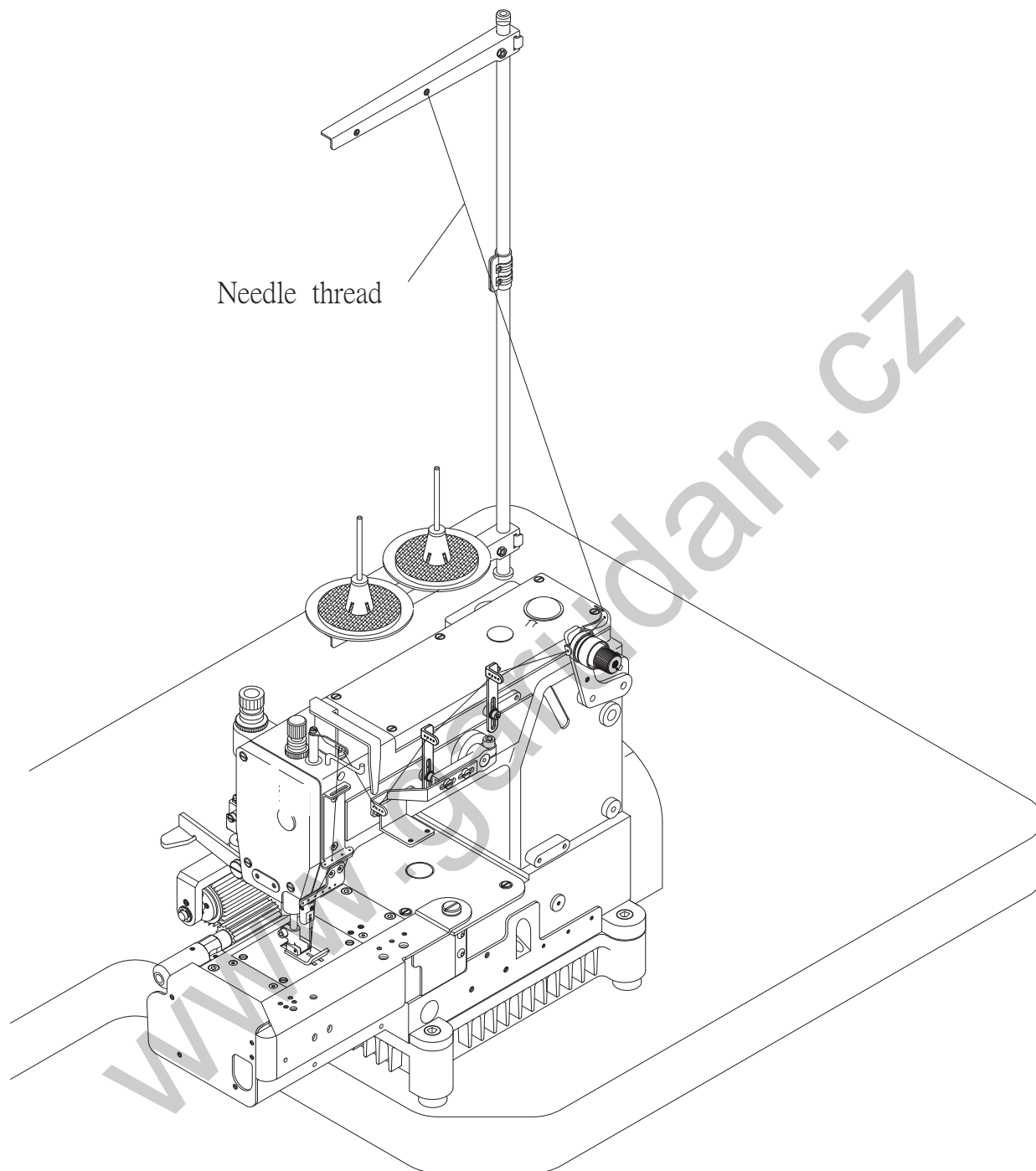

17.THREADING DIAGRAM FOR 4004

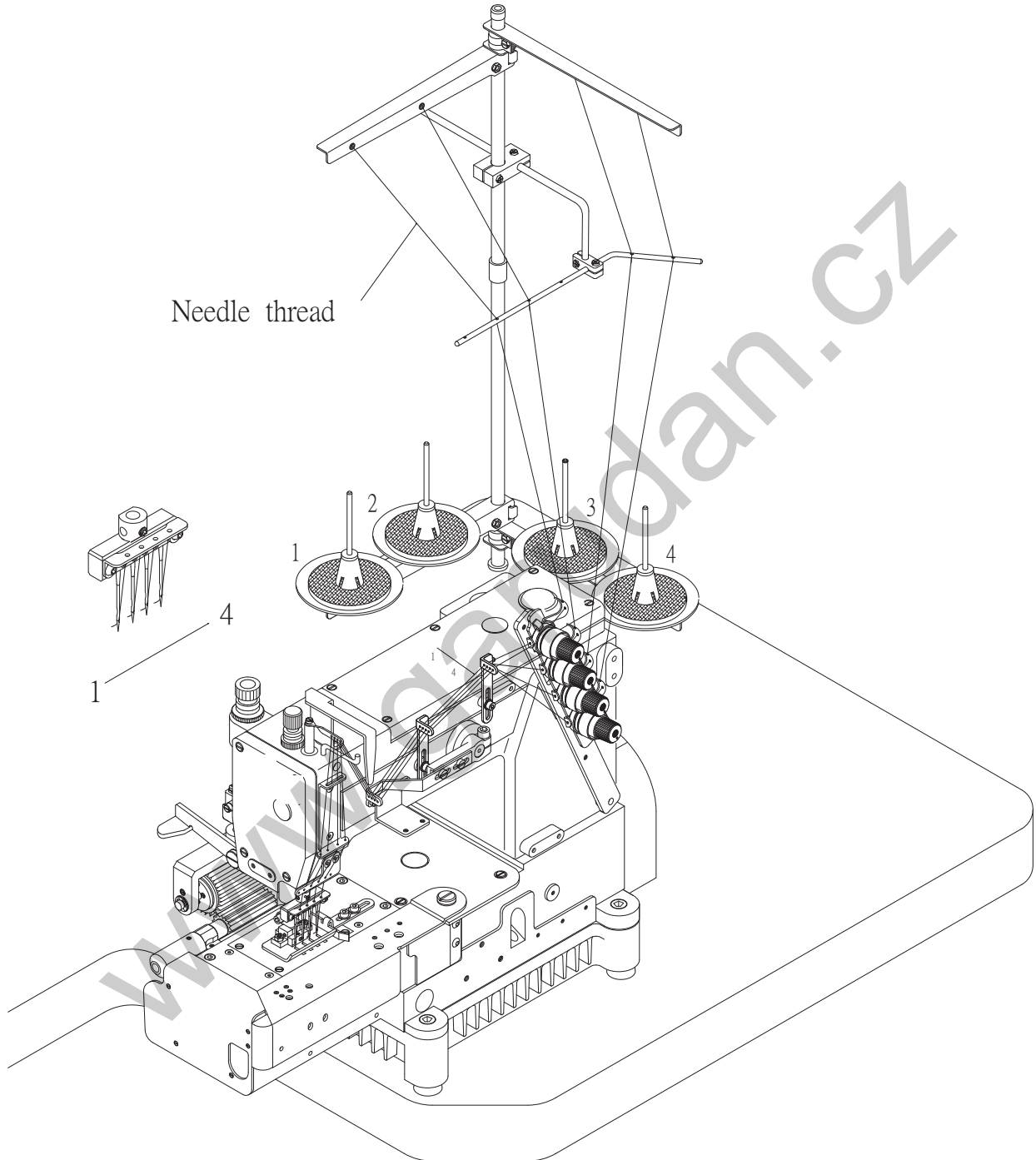

18.THREADING DIAGRAM FOR 4006

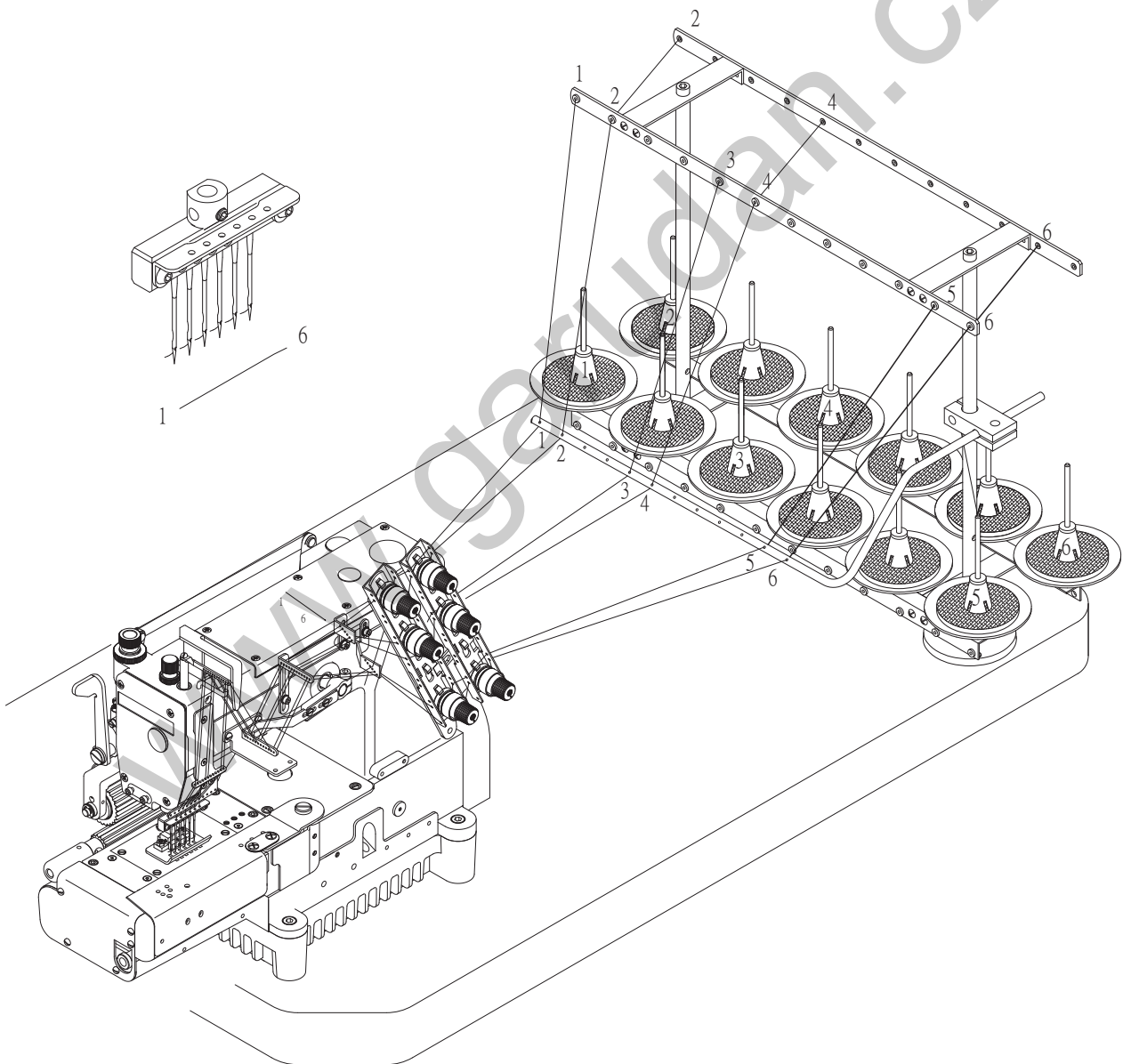
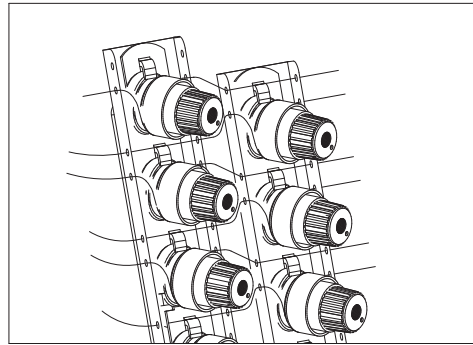

19.THREADING DIAGRAM FOR 4009

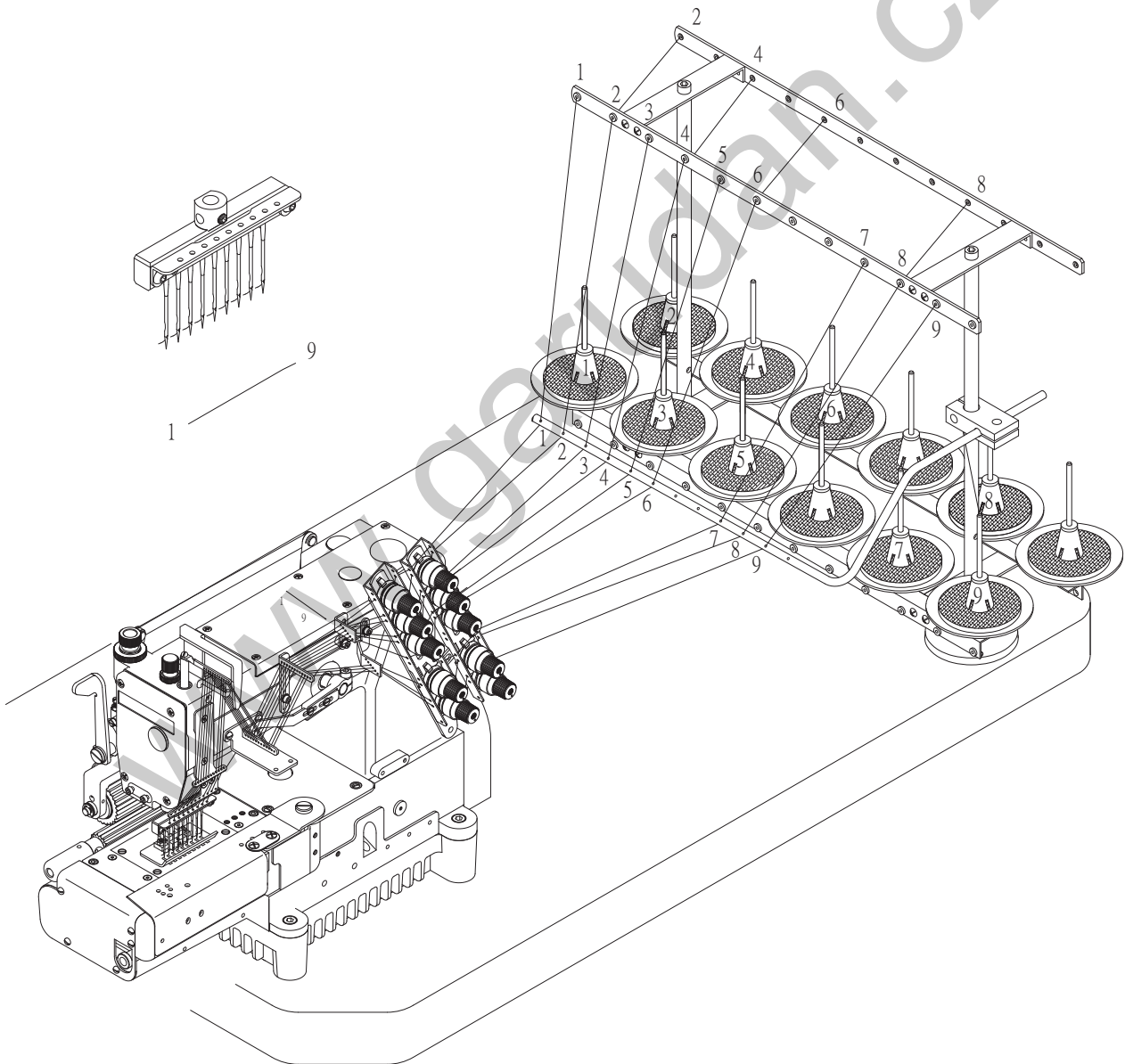
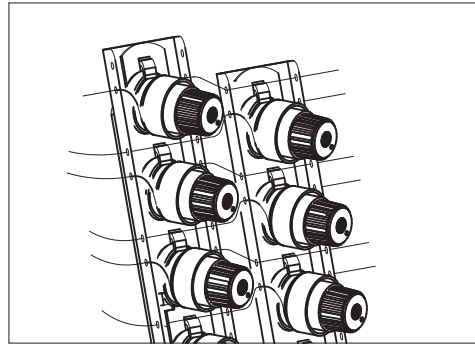

20.THREADING DIAGRAM FOR 4012

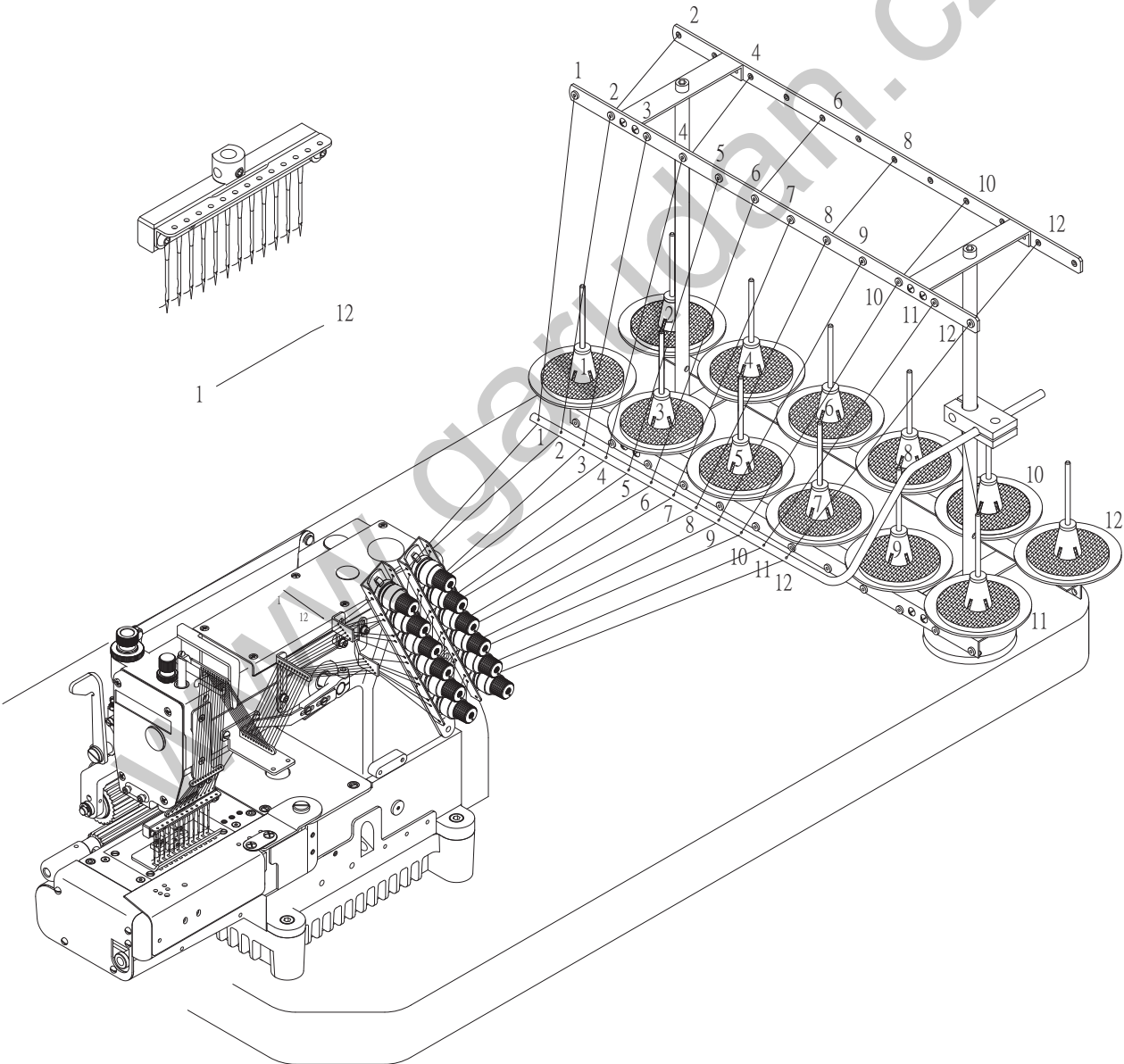
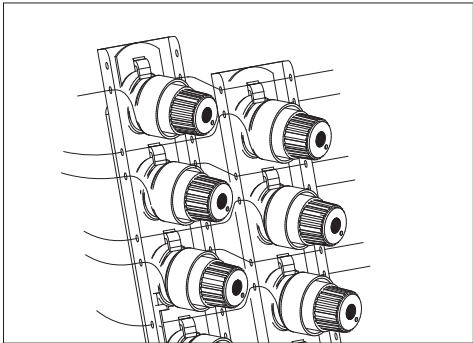

21. ADJUSTING THE STITCH FORMATION

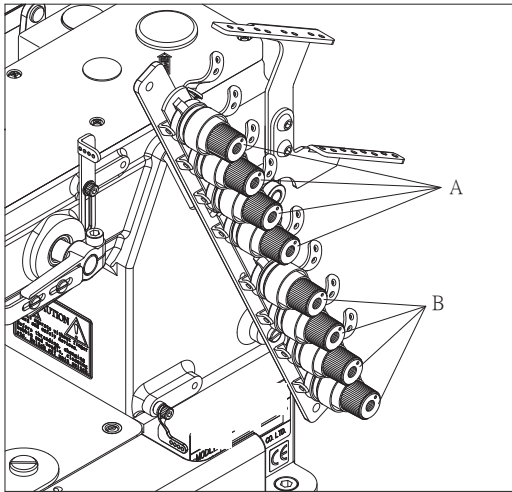

21-1 Thread tension adjustment

Thread tension varies according to sewing conditions such as the fabric, thread and stitch length to be used. Needle thread tension can be adjusted by nuts A. Looper thread tension can be adjusted by nuts B. To increase the tension, turn the nuts clockwise

<NOTE>

The tension should be as light as possible, yet be sufficient to produce uniform stitches.

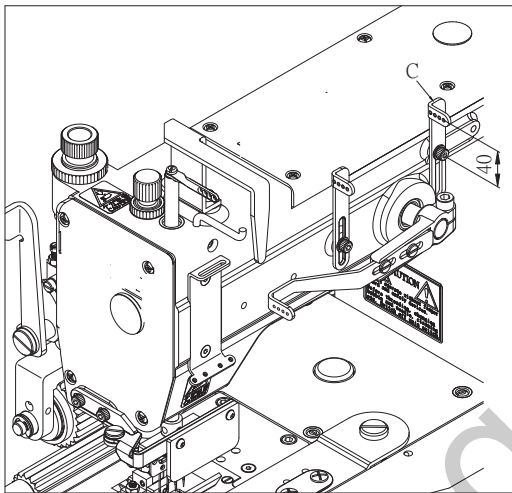

21-2 Position of the needle thread eyelet

Position needle thread eyelet C so that the distance from the center of the screw to the eyes of C is approximately 40 mm.

<Note>

Adjust the needle thread eyelet according to the thread to be used. To tighten the needle thread, raise the needle thread eyelet.

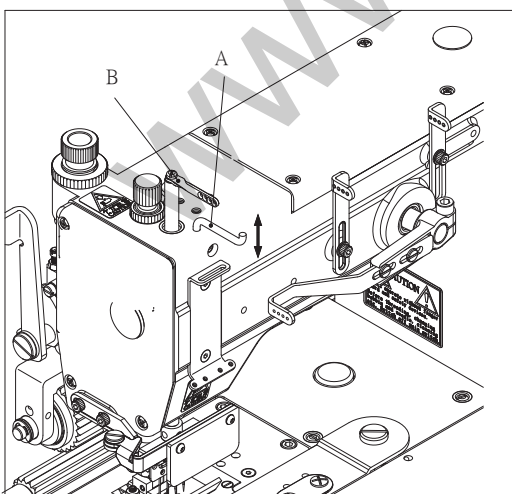

21-3 Adjusting the needle thread guard

With the needle bar at the bottom of its stroke, the centers of the eyes on needle bar eyelet B should be level and parallel with the top surface of needle thread guard A.

<Note>

Raising needle thread guard A increases the size of the needle thread loop.

Lowering needle thread guard A decreases the size of the needle thread loop.

22.TIMING OF THE LOOPER TO THE NEEDLE

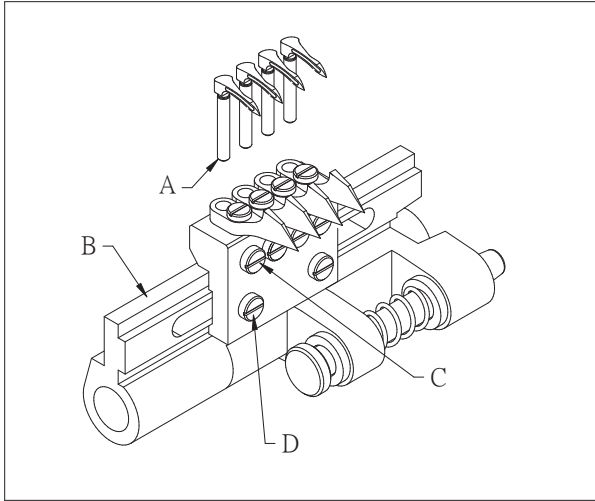

22-1 Positioning the looper and the looper rocker
 Insert the looper into the looper holder until bottom A of the looper touches looper rocker B.
 Then tighten screw C.

Install the looper of the MT Series at a 2° angle. Difference in level within 15mm is approximately 0.5mm. The clearance between the looper and the needle when the point of the looper passes the scarf on the needle should be 0~0.1mm.

Adjustment is made by loosening screw D and moving the looper rocker to the left or right as required.

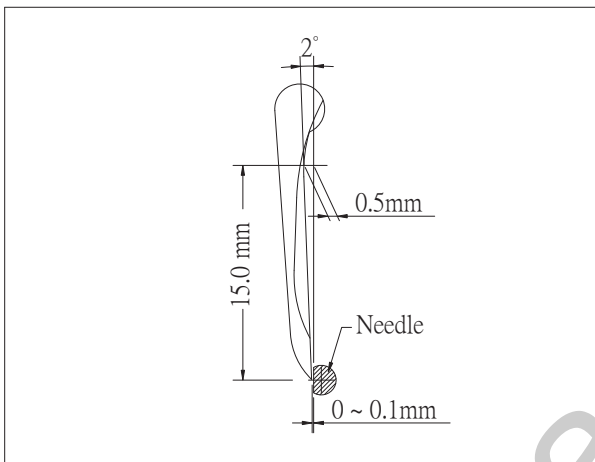

22-2 Looper left-to-right movement

The timing of the looper to the needle is as follows : When the point of the looper, moving to the right, has reached the center of the needle, the point of the looper should be 1.5mm above the top of the needle's eye.

When the point of the looper, moving to the left, has reached the center of the needle, the point of the looper should be 2.3mm above the top of the needle's eye.

For single chainstitching , when needles move wpsrds from lowest dead point , the looper will moves from left to right , by the time when looper moves to the upper edge of needle eye , the distance between the tip of looper and center position of needle eye should be 2 m.m.

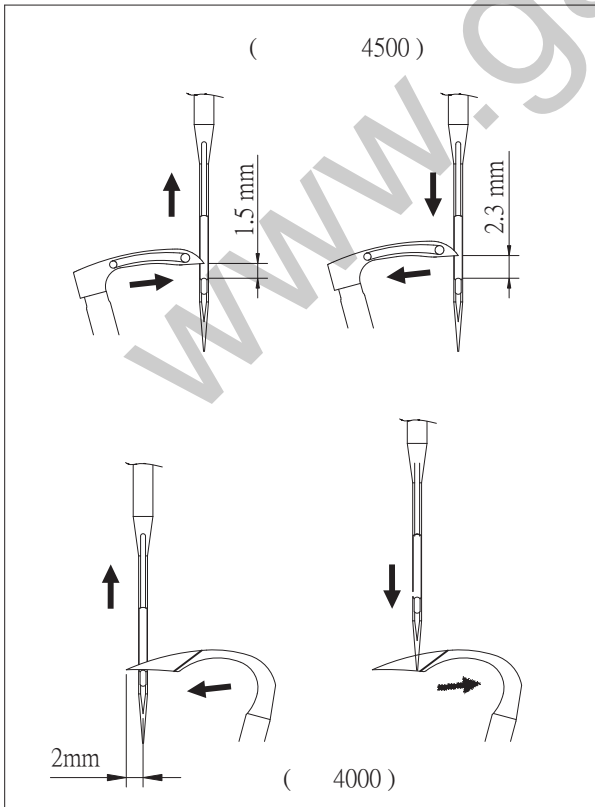

When adjusting, remove the top cover first. Loosen screw D. Then , adjust eccentric A. For standard position , marks C is turned upward when the needle is at the top of its stroke and in line up with on both eccentric A and B

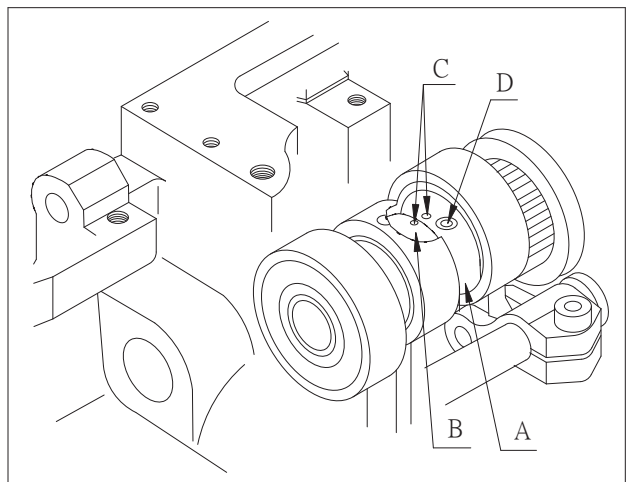

23. TIMING OF THE RETAINER LOOPER

23-1 Installing the retainer looper

Install retainer looper A with its flat surface turned upward. There should be a clearance of 0.6~0.7mm between the needle and the point of the retainer looper. After this adjustment, tighten screw B.

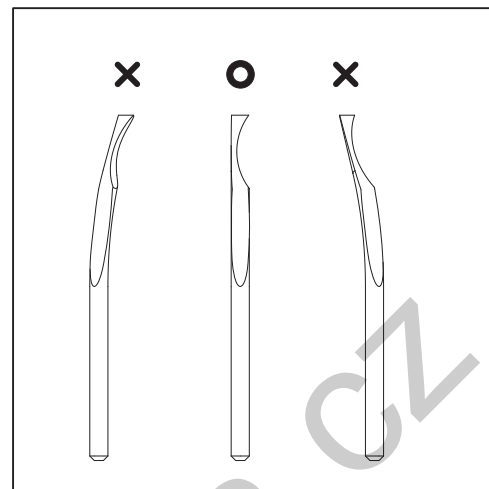
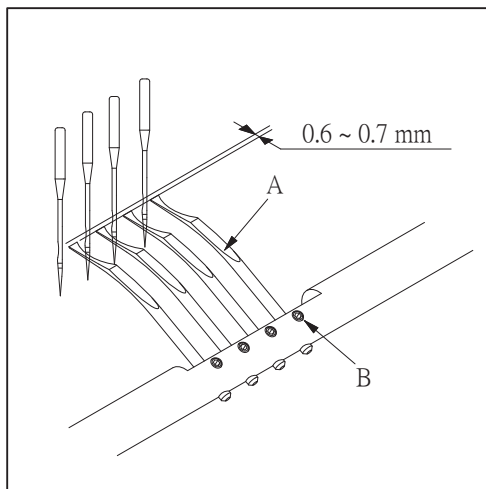

23-2 Timing of the retainer looper to the needle

When the needle, descending from the top to the bottom of its stroke and entering the triangle formed by the looper thread, has reached approximately 4.5mm below the point of the looper, the retainer looper should be at the extreme right end of its travel. When the looper's eye is close to the point of retainer looper while the needle bar is ascending to the top of its stroke, there should be a clearance of 0.3mm between the right side of the retainer looper and the looper. When the needle bar is at the top of its stroke, there should be a clearance of 0mm between the right side of the retainer looper and the top surface (heel) of the looper blade.

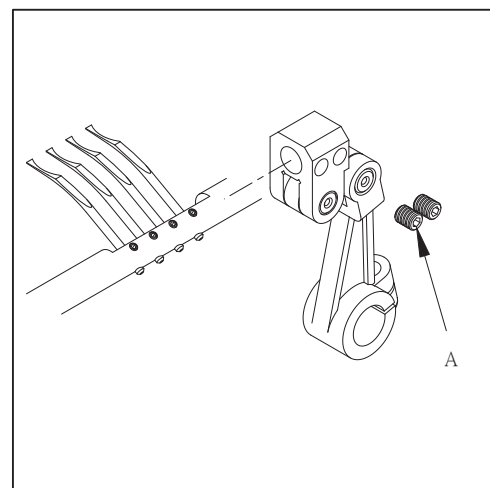
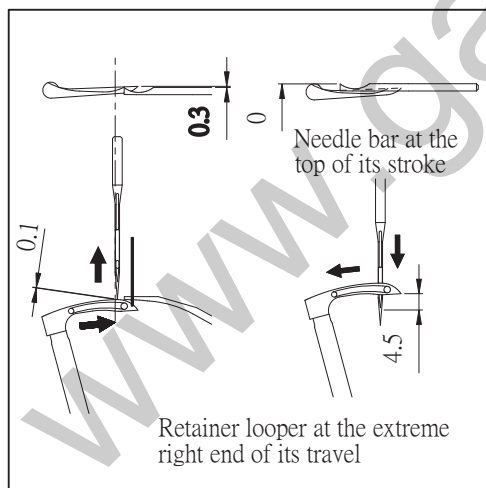

24. ADJUSTING THE NEEDLE GUARD

Position of the needle guard

When the right side of the needle is at the closest to needle guard A, there should be a clearance of 0~0.1mm between them. Adjustment is made by loosening screw B.

<NOTE>

For specification of needle guard, loosen the looper set screw after positioning the looper rocker, adjust the needle guard and then tighten screw B.

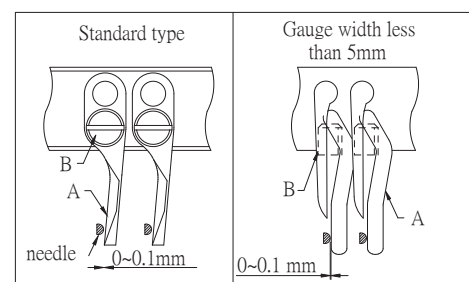

25. ADJUSTING THE FEED DOG & STITCH LENGTH

25-1 Feed dog height & tilt

When the needle bar is at the top of its stroke, the feed dog teeth should be 1~1.2mm above the top surface of the needle plate. Adjustment is made by loosening screw A. Tilt adjustment is made by inserting a tool thru D and adjusting screws B and C. After adjustment, make sure the feed dog is parallel with the top surface of the needle plate.

<Note>

Before adjusting the height of the feed dog, tilt the looper holder first.

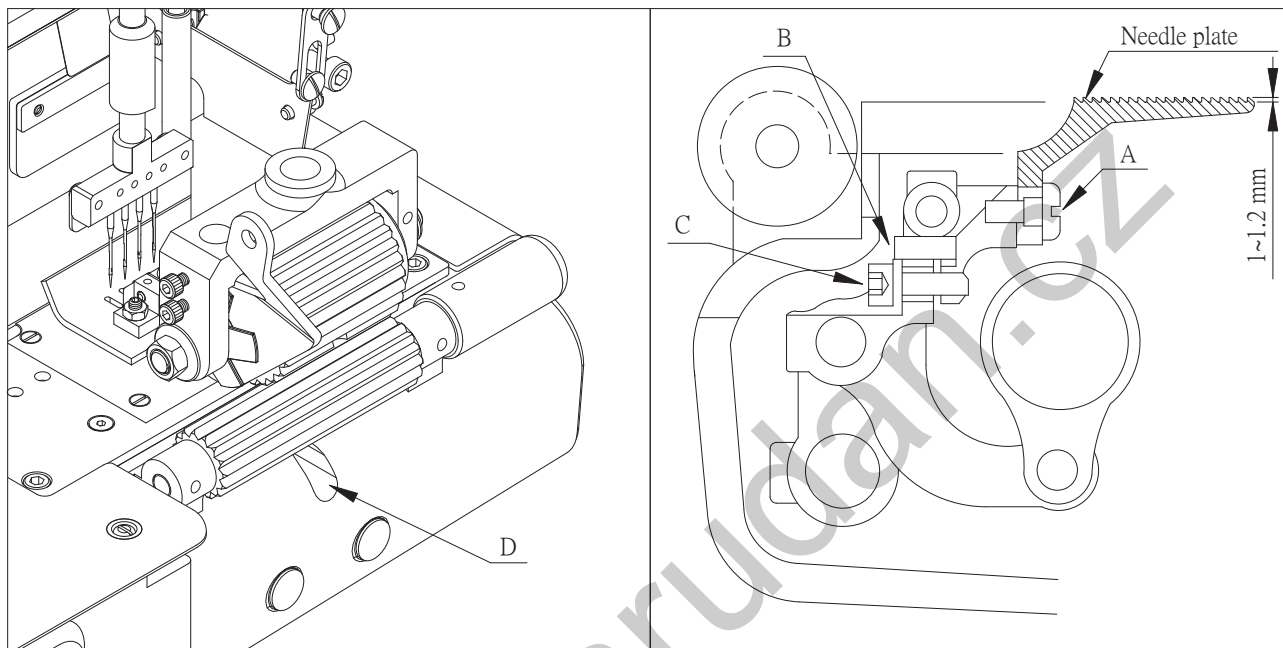

25-2 Stitch length

The stitch length can be adjusted from 2 to 5mm with no step.

The following table shows the stitch length with the number of stitches within 1 inch (25.4mm) and 30mm.

Position of pulley	Stitch length (mm)	No. of stitches	
		Within 1"	Within 30mm
S	2	13	13
M	3	8.5	8.5
L	5	5	5

To change the stitch length

1. Press push button A lightly with the left hand until the end of push button A touches an inside part and clicks.
 2. With push button A depressed, turn the hand wheel with the right hand until the push button goes further into the depth.
 3. Press the push button strongly again.
- Then turn the machine pulley to select the stitch length as required.
4. Align the desired stitch length with alignment mark B.
- Then release the left hand.

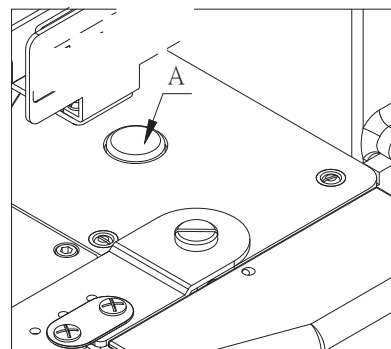
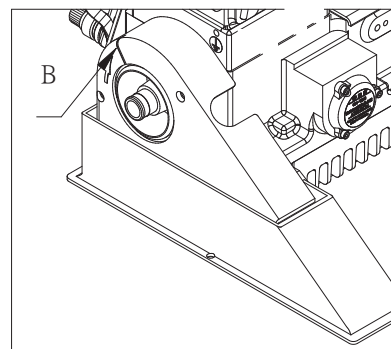

26. ADJUSTING THE PRESSER FOOT

26-1 Presser foot pressure

The presser foot pressure should be as light as possible, yet be sufficient to feed the fabric and produce uniform stitches. To increase the presser foot pressure, turn the adjusting knob clockwise (see the illustration).

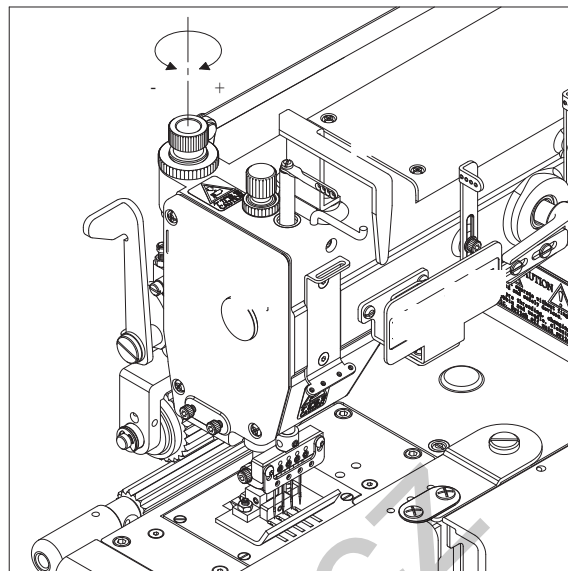

26-2 Position of the presser foot and foot lift

Fit the presser foot properly onto the presser bar.

Make sure the needle is in the center of the needle drop hole on the presser foot when the needle is descending.

Adjustment is made by loosening screw A. There should be a clearance of 0.5mm on both sides between presser foot base and connection base as shown in the illustration in order to keep presser foot in horizontal position.

Adjustment is made by loosening nuts B

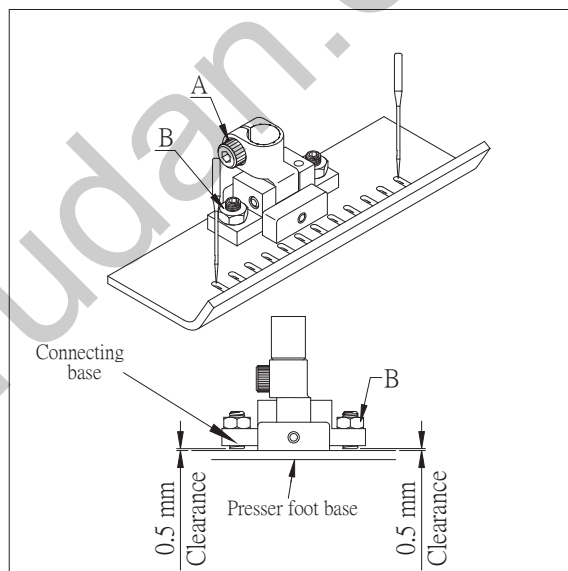

Foot lift

Position stopper C with the presser foot approximately 10mm above the surface of the needle plate and then tighten nut D.

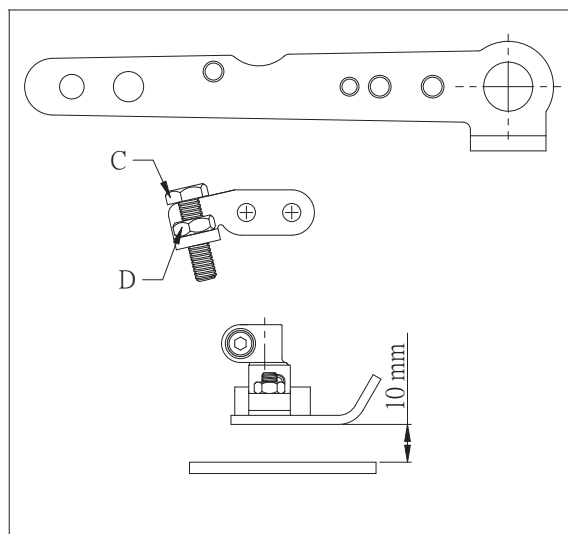

27. ADJUSTING THE REAR PULLER DEVICE

27-1 Manual lever and position of the stopper

To feed or remove the fabric, raise manual lever A. With the manual lever lowered, hold stopper B so that the clearance between the upper and lower pullers is 0.5mm. Then tighten nut C.

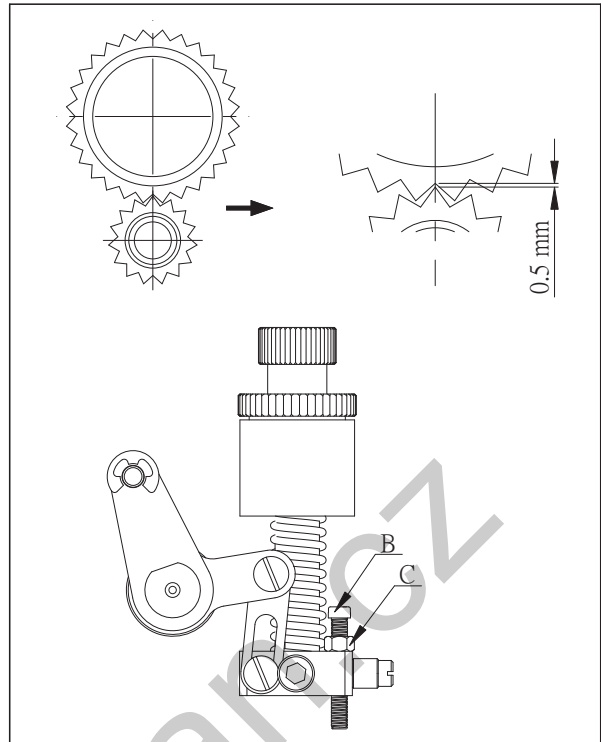

27-2 To adjust the puller pressure

The puller pressure should be as light as possible, yet be sufficient to feed the fabric smoothly.

To increase the pressure, turn adjusting knob D clockwise. To decrease the pressure, turn adjusting knob D counterclockwise.

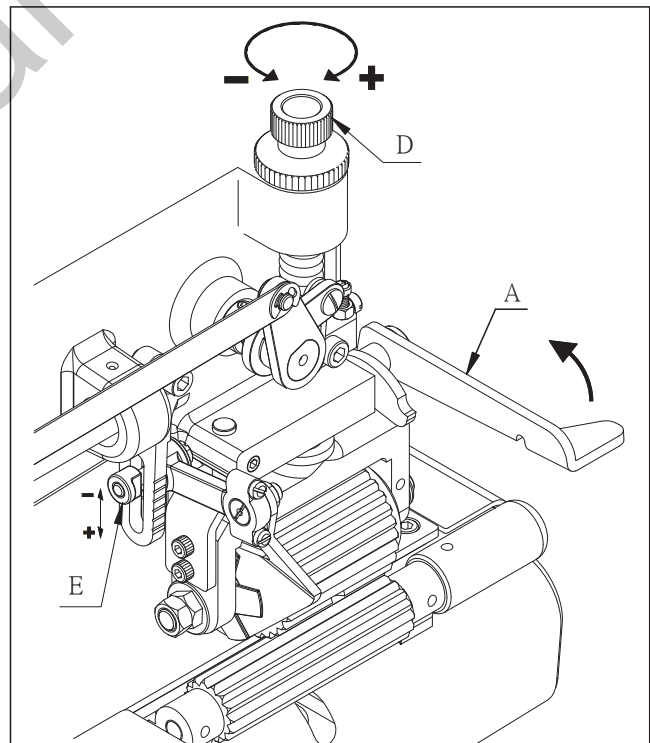

28. CLEANING THE MACHINE

At the end of each working day, remove the presser foot and the needle plate and then clean the slots of the needle plate and the area around the feed dogs.

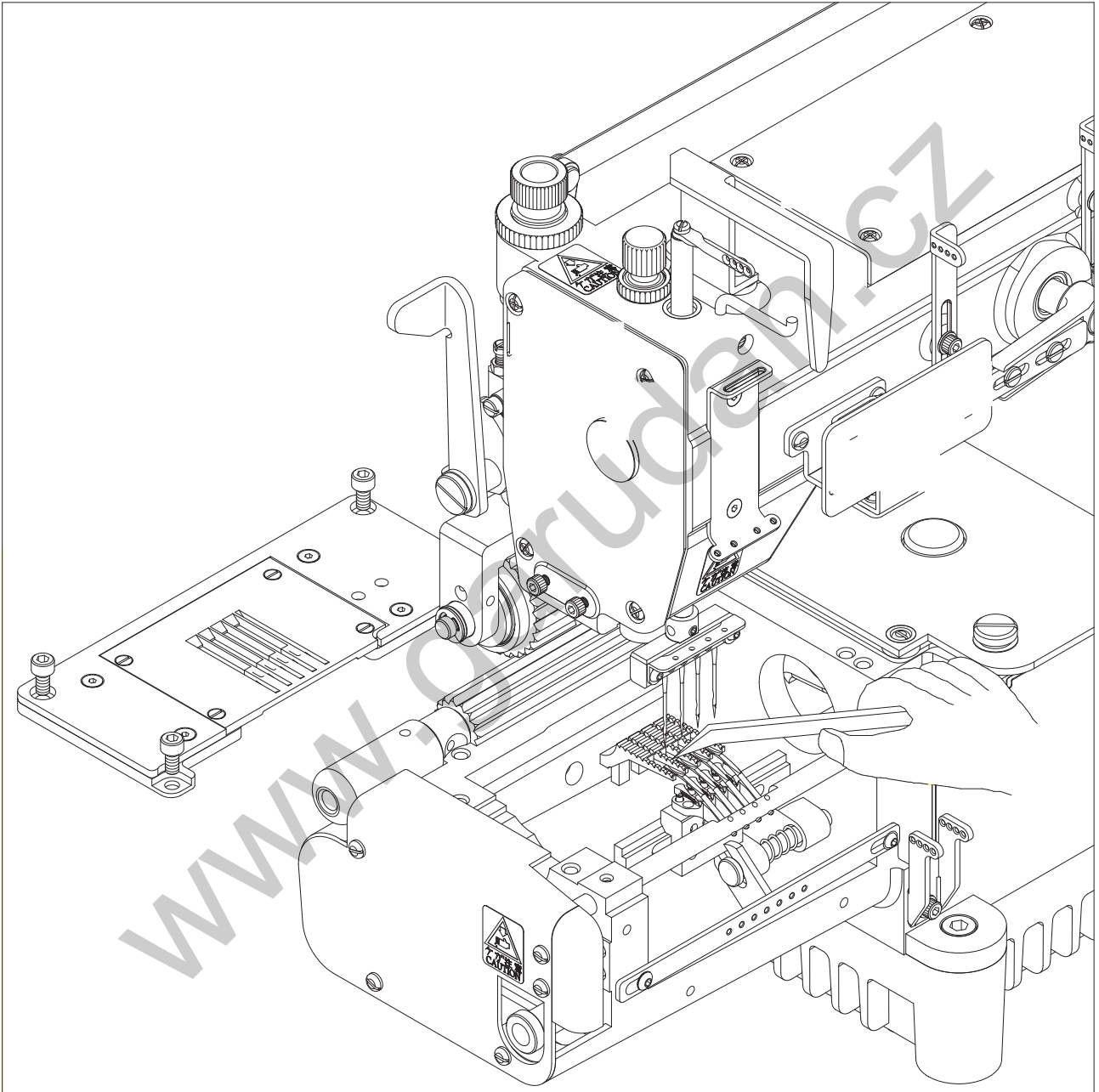

IMPORT SAFETY INSTRUCTION

1. Transportation

- (1) The machine packed with two pieces of cover that made of expanded polystyrene.
- (2) Put the machine into a export carton.
- (3) Use a cart or by two men's hands to move it.

2. Storage

- (1) The machine must use dustcover to cover it when it does not work.
- (2) Avoid to storage the machine in the room temperature more than 45°C .

3. Working

- (1) The machine doesn't work properly when temperature over 40°C .

4.Warning

Pay attention to these warning advices as follow :

- A: Working area is dangerous.
- B: Never touch the needle when the machine is still running.
- C: Be careful when you feed the fabric.
- D: Do not insert your finger between needle and puller during sewing operation.

5. Pay attention to the warning sticker.

- A: movable parts must be cover with guard when you operate.
- B: pull out the plug from socket first when you adjusting , threading , changing bobbin or cleaning.