

User manual and  
Spare Parts List

**GARUDAN**<sup>®</sup>

**GP-518 – 141**

**GP-528 - 141**

**GP-538 - 141**



ANITA B, s.r.o.

Hliníky 2068

680 01 Boskovice

Czech Republic

tel: +420 516454774, 516453496

fax: +420 516452751

e-mail: [info@anita.cz](mailto:info@anita.cz)

[www.garudan.cz](http://www.garudan.cz)

## 1 Safety Measures

Do not put the machine into operation until an appropriate preparation is carried out by a specialist or an authorised person, and until you get acquainted with safety measures.

1. Any sewing machine may be operated only by a properly trained operator.
2. Take into consideration the safety regulations valid in your country.
3. The sewing machine may be used only for the operations for which it has been designed. Other operations are inadmissible.
4. All safety measures must be observed on the machine before putting into operation and during operation.
5. It is advisable to wear protective glasses to ensure personal safety when working on the machine.
6. If you are going to make any modifications or changes on the machine observe the safety regulations. Modifications can only be made at your own risk.
7. The main switch of the machine must be switched off or the plug must be pulled out of the socket of mains supply when following operations are to be performed (if you use mechanically controlled clutch motors without a fuse preventing the machine from being started with the pedal wait until the motor stops).
  - 7.1 Threading the needle thread (threads), threading the looper thread, etc.
  - 7.2 Replacing needles, presser foot; stitch plate, looper, looper bobbin, feed dog, needle guard, finger guard, cloth guide, etc.
  - 7.3 When you leave the workplace and when you leave the machine unattended.
  - 7.4 Machine maintenance (cleaning).
8. Repairs, maintenance and modifications of the machine (see point 6) may be carried out only by a specialist or an authorised person. Only spare parts supplied by the machine builder should be used for repairs.
9. Works on the electrical parts of the machine can only be carried out by an electrician or under an authorised person's control and supervision.
10. Working on "live" parts and equipment is inadmissible.
11. Compressed air supply has to be disconnected before maintenance and repairs of pneumatic devices. Residual compressed air has to be let off before the works can be done.
12. The user will be held responsible if safety measures given in the Instructions for Use are not observed.
13. An inseparable part of the Instructions for Use is the Instruction for use of the respective drive which must be observed, as well. In particular point 3 "Safety Instructions".

## 2 Putting the machine into operation



Following instructions must be observed to avoid risk of failures or damage to the machine:

- clean the machine of preserving agents
- drop 1-2 drops of oil into looper
- remove the front cover and oil the ends of needle bar connecting-rod and of the cross-head slide of thread take-up.
- a specialist shall check if the electrical equipment is in good order incl. necessary voltage for motor and see to it that machine hand wheel rotates towards the operator (see arrow) when the electric motor is connected.
- do not run the machine at full speed during the first two weeks, sewing should be performed at ca. 3/4 of the maximum speed.



### Caution!

Do not interfere with the electric equipment of the machine, call an electrician. Danger of electrical accident. When working on the machine or close to the machine take care that you do not give cause to an accident. See to it that no liquid can get into the electrical equipment and cause a short-circuit or any other failure of the electrical equipment.

Observe the generally valid safety regulations.

When running the machine, be very cautious especially near the needle, trimming knives, thread take-up and cloth pressing elements.

When the machine head is tilted on its support, take special care so that the whole machine and support may not tilt over.

To tilt the machine into working position take the head with both hands to avoid any injury between the tilted machine and the base plate.

### 3 Threading the Upper Thread



#### Caution!

Switch off the main switch and remove your feet from the pedals on the machine support before threading so that the machine may not be started by unintended treading on the pedal.

When threading the thread from bobbin stand into needle follow figure 1 for single needle machine. The thread pass from bobbin stand to thread guides on the machine head (A, B) through auxiliary tensioner and thread guide (C), through tensioner (D), tension spring (E) and thread take-up lever to the needle. The thread enters the eye from the side with a long groove. On single needle machines threading should be carried out according to figure following the arrow S.

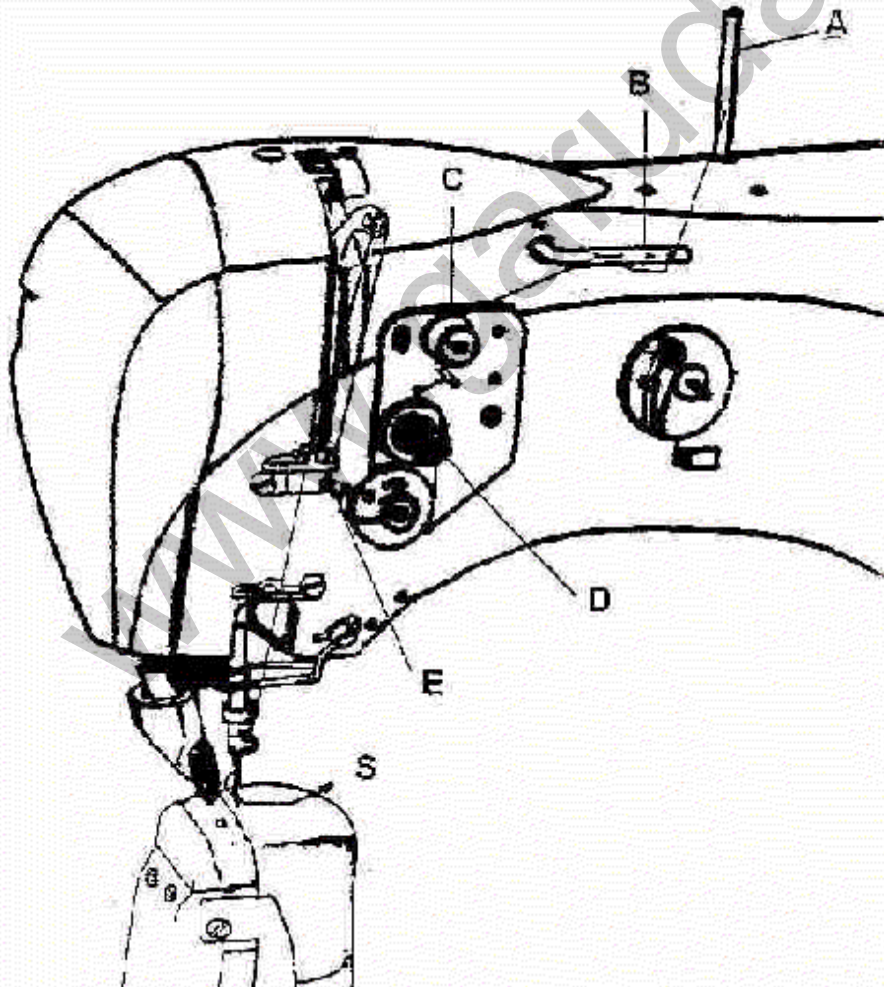

Fig.1

#### 4 Inserting needles



#### Caution !

Switch off the main switch and remove your feet from the pedals on the machine support before replacing needles so that the machine may not be started by unintended treading on the pedal.

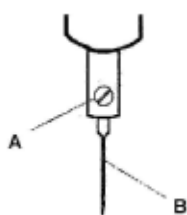

Fig.3

Having chosen the right thickness (size) of needle whose system corresponds to the prescribed kind (usually 134 LR) loosen screw (A, fig.3) on needle bar and insert needle (B) as far as it will go, i.e. up to the bottom of the needle hole in the needle bar. Turn the needle so that the recess above the needle eye faces the looper point. Caution – when a greater needle size has been chosen it is necessary to check if the looper point does not catch the needle – a possible adjustment of looper position must be carried out by an authorised person. Make sure that the needle passes through the middle of the stitch plate opening. If it is not the case, check up if the needle is not bent. Replace the defective needle.

#### 5 Replacing Hook Bobbin, Threading Hook Thread

The thread passes from the bobbin case (A) through slot (B) under spring (C) into the looper (fig. 4) in such a way that the thread will be unwound from the bobbin in the direction of the arrow. Hold a thread end of ca. 5-6 cm and insert the bobbin case containing bobbin into the hook in such a way so that the thread can be unwound from the bobbin smoothly. Lock the bobbin case (A) in the looper using the lock (E).

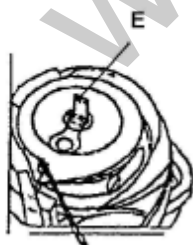

Fig.4

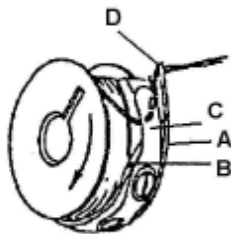

Fig.5

Use screw (fig. 5) to adjust the tension of the thread unwound from the bobbin. Turn it in the (+) direction to increase the thread tension or in the (-) direction to decrease the tension.

**Caution!**

Do not start the machine until you put the hook covers in working (protecting) position. Switch off the main switch and remove your feet from the pedals on the machine support before replacing the hook bobbin so that the machine may not be started by unintended treading on the pedal.

**6 Adjusting Stitch Length****Caution!**

Switch off the main switch and remove your feet from the pedals on the machine support before adjusting stitch length so that the machine may not be started by unintended treading on the pedal.

Push in the stitch length adjusting knob (A) in the column of the machine arm (fig. 6) and turn the hand wheel until the knob locks deeper into the arm. Turn the knob in the direction of arrow (+) to increase the stitch length or in the direction of arrow (-) to reduce the stitch length. Adjustment is determined by the position of the tip of pointer (C) against division lines on the disk of hand wheel (B).

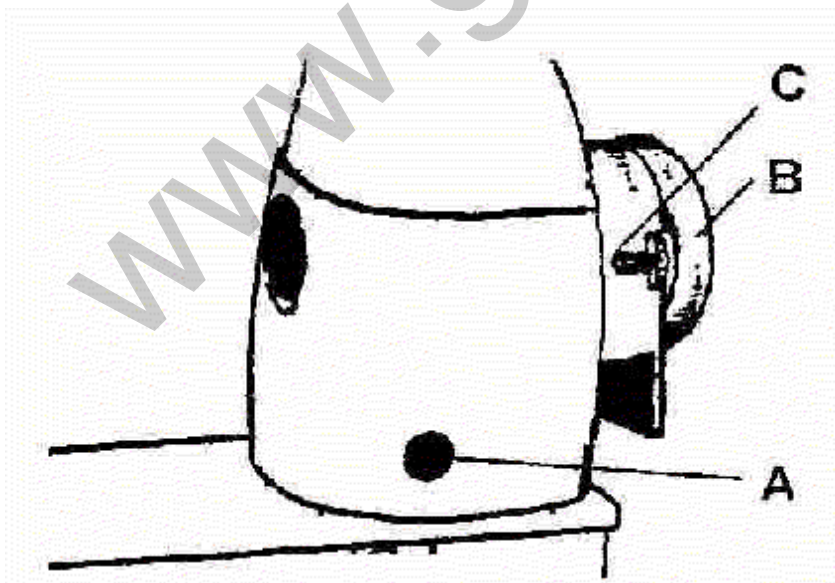

Fig. 6

## 7 Adjusting Differential Feed Ratio

(only for machines with driven presser foot)

To ensure sewing of fabric layers without their displacement in the course of feeding it is possible to adjust different lengths of feeding driven by press-wheel and feeding by rotary feed dog. To adjust shorter lengths of feeding driven by press wheel move collar (A) on lever (B) towards feeding shaft (D). To increase the length of press-wheel feeding move collar (A) from the axis of shaft (D).

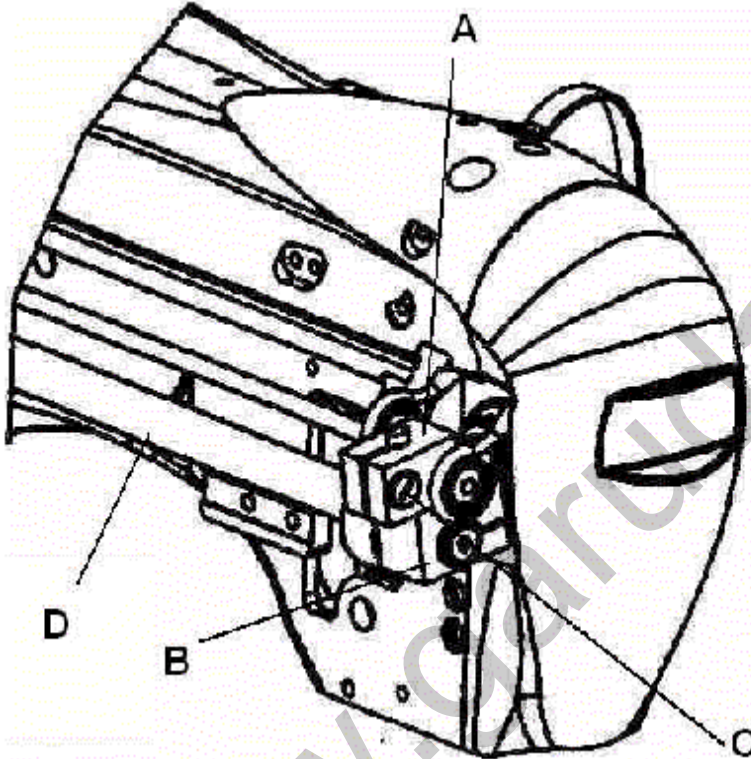

Fig. 7

An appropriate adjustment of the ratio of the lengths of feeding driven by rotary feed dog and press-wheel makes it possible to achieve not only the same feeding of fabric layers but, if necessary, to gather or stretch one of the fabrics.

## 8 Safety Clutch

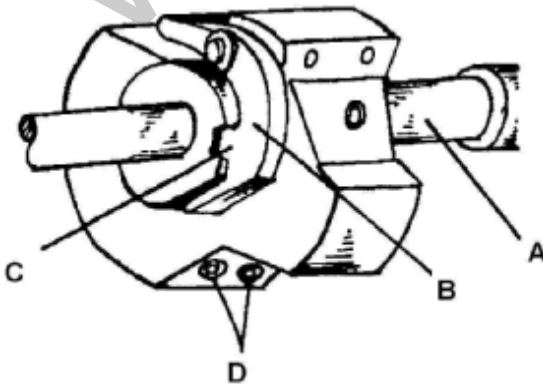

Fig. 8



The sewing machines are equipped with a safety clutch on the lower shaft (A) fig. 8 that allows the operator to turn the driving part of lower shaft (A) when the loopers or feed dogs are locked. The clutch consists of segment (B) engaging with groove (C) in the disk on lower shaft by the pressure of two springs. The spring pressure can be regulated with hexagon screws (D). If the clutch is skipping over find out the cause and remove the fault. Only a specialist is allowed to adjust the clutch force. The clutch must not slip in the course of normal sewing! If it is the case call a specialist to examine and adjust the machine.

## 9 Maintenance



### Caution!

Switch off the main switch and remove your feet from the pedals on the machine support before cleaning and oiling of the machine so that the machine may not be started by unintended treading on the pedal.

### Cleaning:

Keep the machines clean and at least once a day (depending on the fabrics used) remove dirt and waste from the looper and feed dog area. If the machine is equipped with a thread trimmer clean the trimming area, as well. Do not use volatile liquids for cleaning they would cause damages to the machine and to your health. A dry cloth will do. Check if the filter screen on electric motor is not clogged with dust.

### Oiling:

The machine should be oiled with an oil normally used for sewing machines. Every day, before you start sewing drop one drop of oil into oiling holes marked with red colour on the machine. Switching-on and switching-of the main switch.

## 10 Switching Off and Switching On of the Main Switch

The Main Switch are marked 0 and I or they have grey/green and red buttons. Pushing position of the button marked "0" (red) means: off, pushing position of the button marked "I" (grey/green) means on.



### Caution!

Before you start the machine make sure that it is ready for sewing and there is no hard object placed under the needle.

## 11 Function of Pedals and Knee Lever

- On machines equipped with one (wide) pedal the pedal regulates sewing speed. When treading the pedal the sewing speed increases up to maximum speed. If the pedal is in neutral position the machine stops. If the pedal is treaded backwards (with the heel) the machine will - depending on its make and the abilities of the stop-motor - tack, cut the thread and lift the pressing element (press wheel, presser foot). See the Instructions for use of stop-motor for detailed description of the functions.

- On machines equipped with a mechanically operated clutch the pedal regulates sewing speed and stops the machine. Presser foot is lifted with the knee lever.

Note: On machines with stop-motor there may be push buttons (one or more) installed on the machine head. Their function depends on the type of the stop-motor used and their connection is described in the Instruction for use of stop-motor.

## 12 Bobbin Winder – Standard Built in

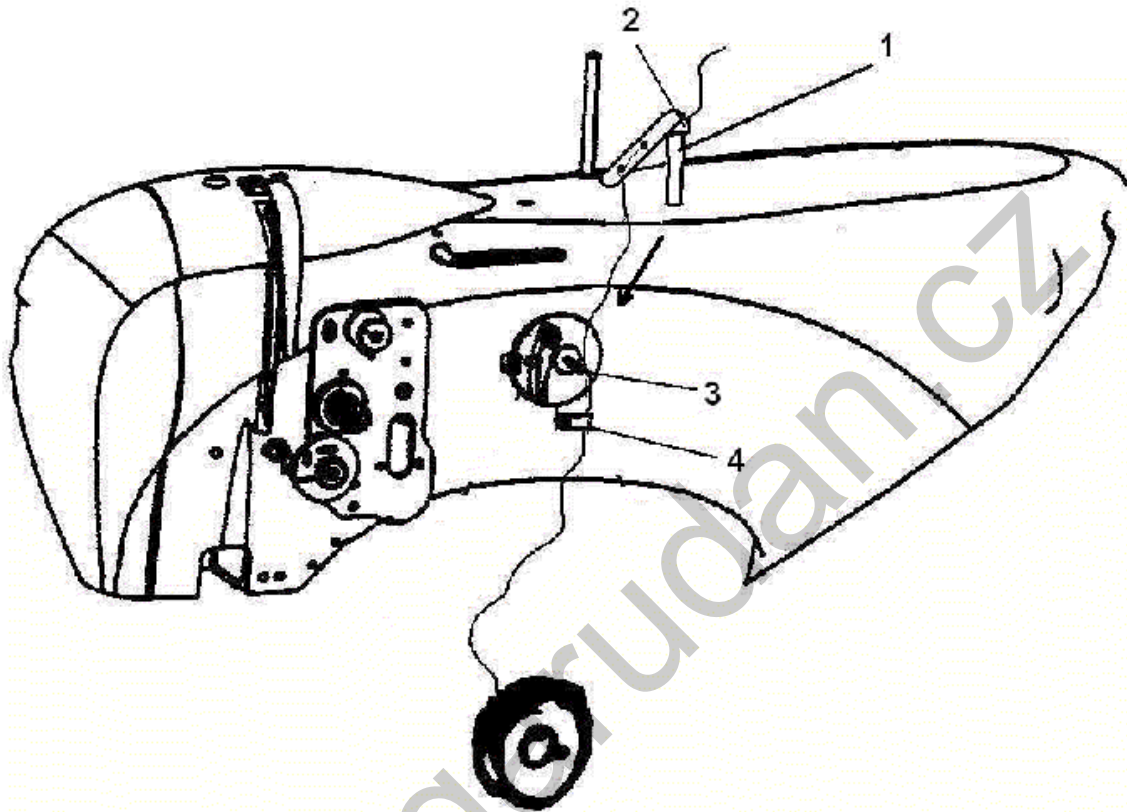

Fig. 9

The thread passes from the bobbin stand through thread guide on the winder bracket (1) and between tension disks (2) and then following the direction of arrow (S) to the empty bobbin. Install the empty bobbin on the bobbin winder shaft (3). Wrap the bobbin thread around the empty bobbin in a clockwise direction and push in.

The bobbin winder will stop automatically when the bobbin is full.

Take off full bobbin. Lock the thread under the clip and knife (4). Thread will be cut and kept the bobbin thread from interfering with the needle thread.

## Instructions for adjustment

### 13 Basic condition

- a) Clearance between the throat plate and the bobbin case stopper.

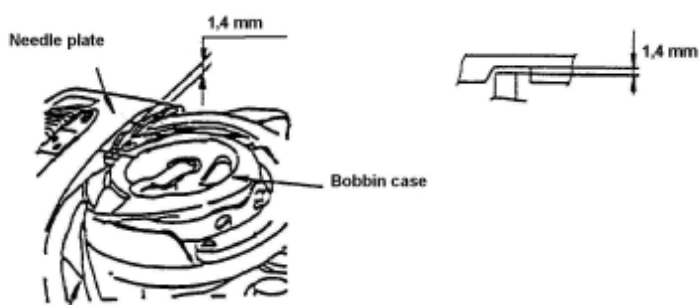

Fig.10

Condition :

Clearance between the top end of the bobbin case resting groove on the throat plate and the top face of the bobbin case stopper of the hook : 1,4 mm .

- b) To adjust the needle height and the hook course. (Fig. 11)

The hook must be so interrelated with the needle that at the moment when the hook point begins to take up the upper thread loop, the upper edge of the needle eye comes approximately  $1 \div 1,2$  mm under the hook point.

Rotate the hand wheel towards you until the needle reaches its bottom position and recends by 3 mm. In this position, the hook point must lie in the needle axis.

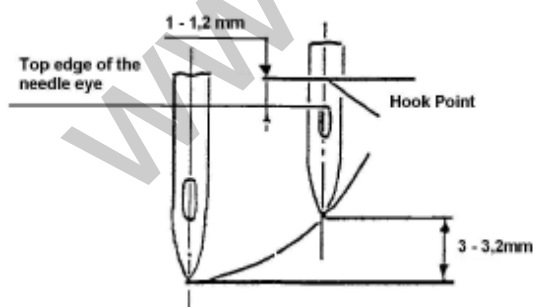

Fig. 11

- c) The range of technological use

Needle: 134 LR size 75 – 130. According to the chosen material, threads and needle gauge it is necessary to choose throat plate (table I3- Parts Book) .

Standard hook. Sewing speed max. – 3300(spm). Stitch length max.-8mm.

## Spare Parts Lists

<b>A1</b>	Frame and Cover Parts, Thread Tension Mechanism.....	14,15
<b>B</b>	Upper Shaft Mechanism.....	16,17
<b>C1</b>	Lower Shaft and Clutch Mechanism.....	18,19
<b>C2</b>	Timing Belt Driving Mechanism.....	20,21
<b>D1</b>	Needle Feed and Driven Roller Mechanism.....	22,23
<b>D2</b>	Lower Feed Mechanism.....	24,25
<b>D3</b>	Feed Shaft Mechanism.....	26,27
<b>D4</b>	Stitch Adjuster Mechanism.....	28,29
<b>E</b>	Needle Bar and Presser Foot Mechanism.....	30,31
<b>F</b>	Thread Take-Up Lever Mechanism.....	32,33
<b>G1</b>	Roller Presser Foot Mechanism.....	34,35
<b>G2</b>	Presser Foot Bar Mechanism.....	36,37
<b>H1</b>	Left Bedplate Feed Mechanism.....	38,39
<b>I1</b>	Feed Mechanism.....	40,41
<b>N1</b>	Bobbin Winder.....	42
<b>N2</b>	Accessories.....	44,45

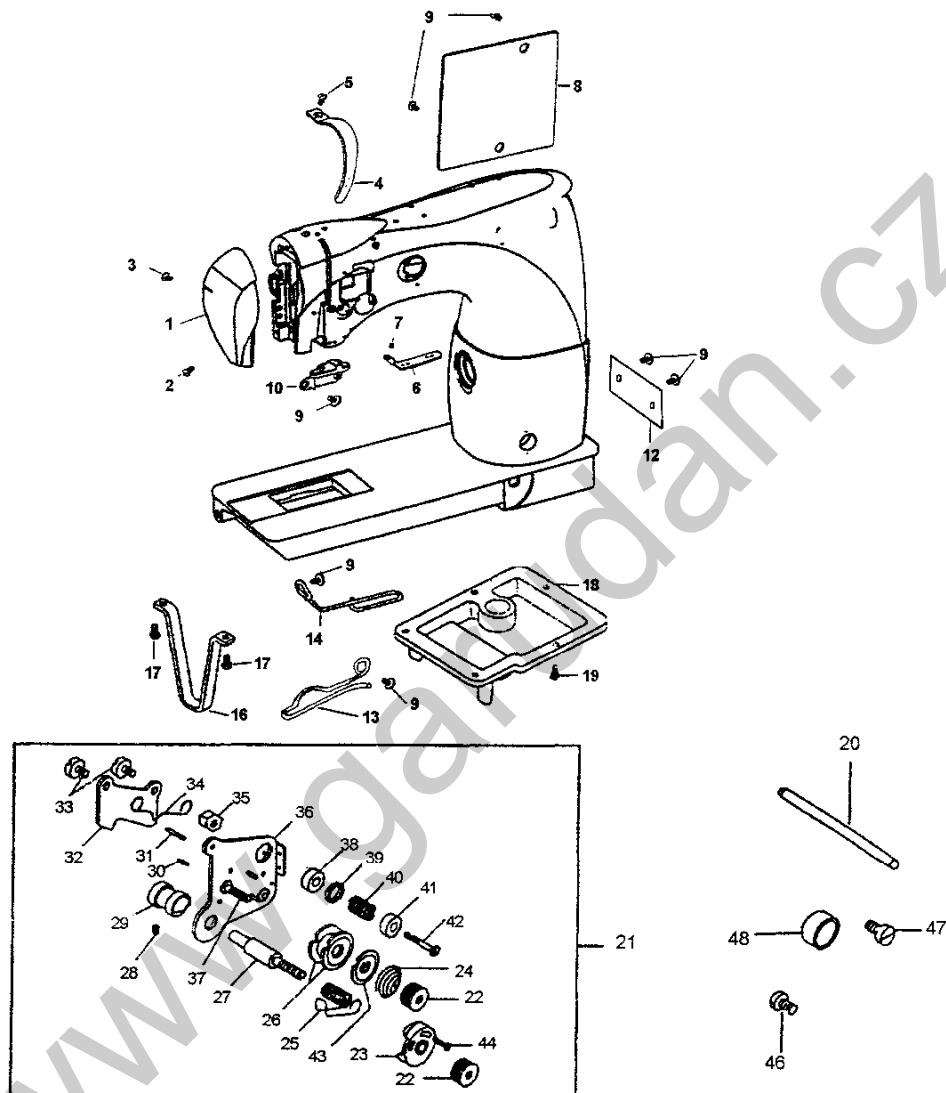

Ref.No.	Part No.	Name of Part	Q'ty
A1-1	GP/5-1	Face Plate	1
A1-2	GP/108246	Screw (M5x0,8x25)	1
A1-3	GP/108234	Screw (M5x0,8x35)	1
A1-4	GP/168061	Thread Take-up Cover	1
A1-5	GP/210210	Screw (M5x0,8x8)	1
A1-6	GP/119027	4 Hole Thread Retainer	1
A1-7	GP/314946	Screw (M4x0,7x4)	1
A1-8	GP/119039-1	Arm Side Cover	1
A1-9	GP/700335	Screw (M5x08x7)	7
A1-10	GP/118430	Thread Guide Wire	1
A1-12	GP/119039-1	Cover	1
A1-13	GP/119686-1	Thread Wire Guide	1
A1-14	GP/119686	Thread Guide Wire	1
A1-16	GP/119092	Bracket	1
A1-17	GP/M6x40	Screw (M6x40 DIN 912)	2
A1-18	GP/119091	Bottom Cover	1
A1-19	GP/108225	Screw (M5x0,8x10)	5
A1-20	GP/118553	Tension Releasing Pin	1
A1-21	GP/119171	Thread Tension Regulator Assy	1
A1-22	GP/119171-1	Nut	2
A1-23	GP/119171-2	Spring Guide Assy	1
A1-24	GP/119171-3	Tension Spring	1
A1-25	GP/119766-1	Thread Take-up Spring	1
A1-26	GP/119171-5	Tension Disc	2
A1-27	GP/119171-6	Thread Tension Stud	1
A1-28	GP/119171-7	Screw	1
A1-29	GP/119171-8	Thread Tension Regulator Bushing	1
A1-30	GP/119171-9	Thread Realising Pin	1
A1-31	GP/119171-10	Pin	1
A1-32	GP/119171-11	Tension Release Plate	1
A1-33	GP/119171-12	Screw	2
A1-34	GP/119171-13	Tension Release Spring	1
A1-35	GP/119171-14	Nut	1
A1-36	GP/119171-15	Upper Thread Tension Plate	1
A1-37	GP/119171-16	Thread Tension Stud	1
A1-38	GP/119171-17	Thread Guide Bracket	1
A1-39	GP/119171-18	Thread Guide Disc	1
A1-40	GP/119171-19	Thread Guide Spring	1
A1-41	GP/119171-20	Thread Guide Cap	1
A1-42	GP/119171-21	Screw	1
A1-43	GP/119171-22	Tension Disc Washer	1
A1-44	GP/119171-23	Screw(M2,5x8 DIN 84A)	1
A1-46	GP/175096-1	Screw (M4x0,7x10)	1
A1-47	GP/700412	Screw (M4x0,7x15)	1
A1-48	GP/700412-1	Bushing	1

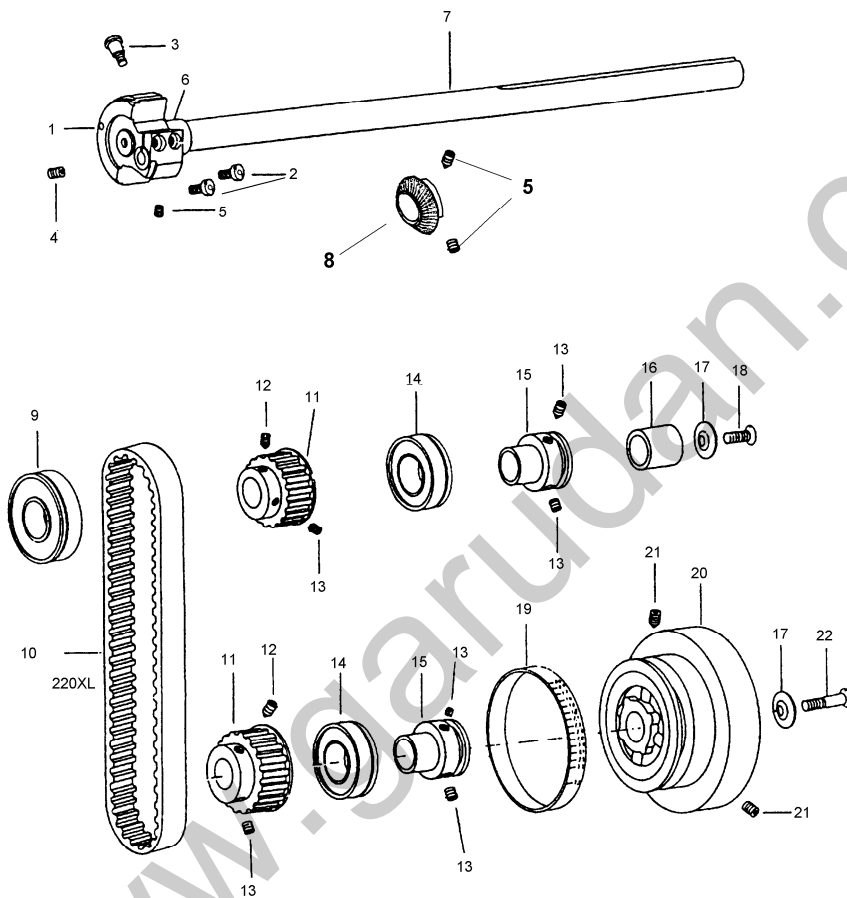



Ref.No.	Part No.	Name of Part	Q'ty
B-1	GP/119702-2	Crank Cam	1
B-2	GP/130224	Screw (M5x0,8x12)	2
B-3	GP/119702-3	Screw (M7x1,0x22)	1
B-4	GP/119702-4	Screw (M7x1,0x16,5)	1
B-5	GP/700510	Screw (M6x0,75x8)	3
B-6	GP/119702-5	Bushing	1
B-7	GP/119702-1	Upper Shaft	1
B-8	GP/200-002	Upper Shaft Gear Winder	1
B-9	GP/018643	Ball Bearing	2
B-10	GP/069160	Timing Belt 220XL	1
B-11	GP/119707	Timing Belt Wheel	2
B-12	GP/335902	Screw (M6x0,75x10)	2
B-13	GP/335902-1	Screw (M6x0,75x8)	6
B-14	GP/016153	Ball Bearing	2
B-15	GP/119705	Upper Shaft Bushing	2
B-16	GP/069746	Bushing	1
B-17	GP/168480	Washer	2
B-18	GP/210265	Screw (M6x1,0x16)	1
B-19	GP/175048	Feed Regulator Scale	1
B-20	GP/170913	Pulley Balance Wheel	1
B-21	GP/341902	Screw (M6x1,0x16)	2
B-22	GP/210287	Screw (M6x1,0x35)	1

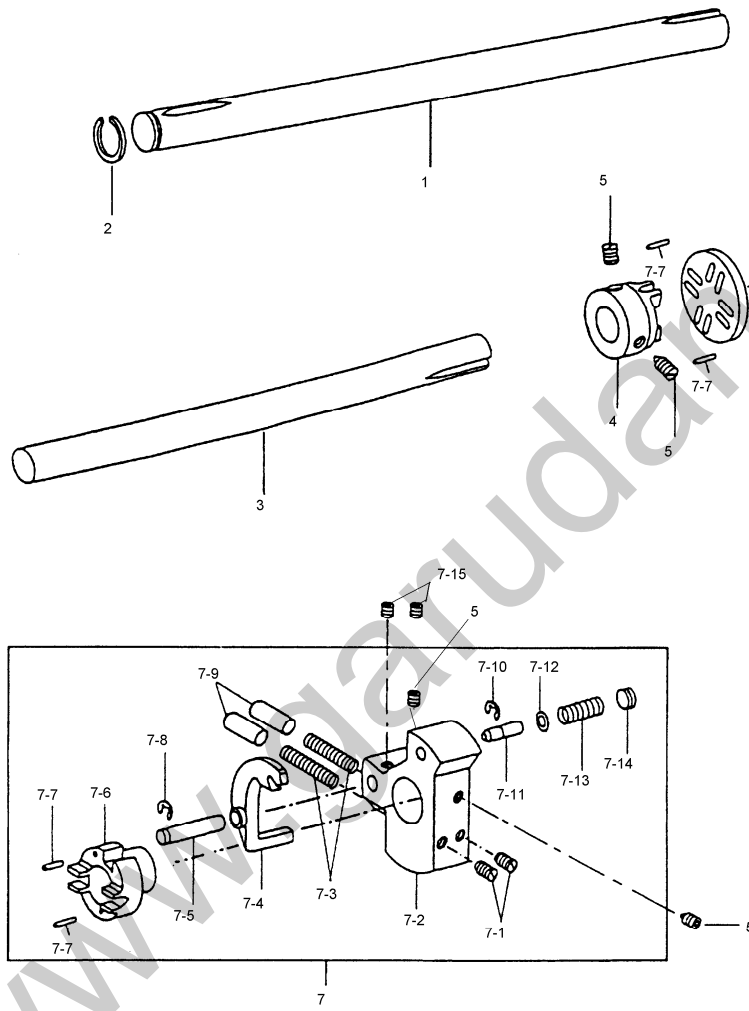

Ref.No.	Part No.	Name of Part	Q'ty
C1-1	GP/175025	Shaft	1
C1-2	GP/518250	Retaining Ring	1
C1-3	GP/119711	Shaft	1
C1-4	GP/175019	Coupler	1
C1-5	GP/341901	Screw (M6x0,75x6)	4
C1-6	GP/133109	Coupler	1
C1-7	GP/119081A	Connecting Plate	1
C1-7- 1	GP/700510	Screw (M6x0,75x7)	2
C1-7- 2	GP/173263	Safety Clutch Seat	1
C1-7- 3	GP/013153	Spring	2
C1-7- 4	GP/173261	Latch	1
C1-7- 5	GP/009408	Hinge Stud	1
C1-7- 6	GP/173264	Coupler (right)	1
C1-7- 7	GP/065052	Pin	4
C1-7- 8	GP/640150	E - Ring	1
C1-7- 9	GP/175023	Stud	2
C1-7-10	GP/640130	E - Ring	1
C1-7-11	GP/013076	Drop - In Pin	1
C1-7-12	GP/069037	Washer	1
C1-7-13	GP/009343	Spring	1
C1-7-14	GP/175126	Screw	1
C1-7-15	GP/M5X5	Screw M5X5 DIN 916	2

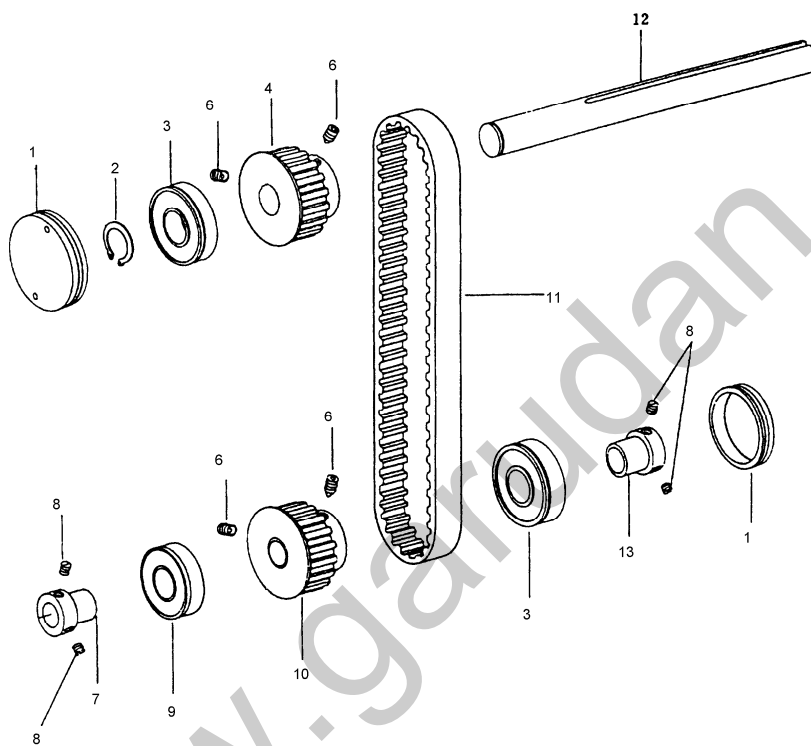

Ref.No.	Part No.	Name of Part	Q'ty
C2-1	GP/119097	Plug	2
C2-2	GP/610300	Retaining Ring	1
C2-3	GP/018624	Ball Bearing	2
C2-4	GP/119707	Timing Belt Wheel	1
C2-5	GP/335902-1	Screw (M6x0,75x8)	2
C2-6	GP/335902	Screw (M6x0,75x10)	2
C2-7	GP/119121	Collar (Left)	1
C2-8	GP/700689	Screw (M6x0,75x4,5)	4
C2-9	GP/018613	Ball Bearing	1
C2-10	GP/119708	Timing Belt Wheel	1
C2-11	GP/069161	Timing Belt 210XL	1
C2-12	GP/119706	Shaft	1
C2-13	GP/118722	Collar (Right)	1

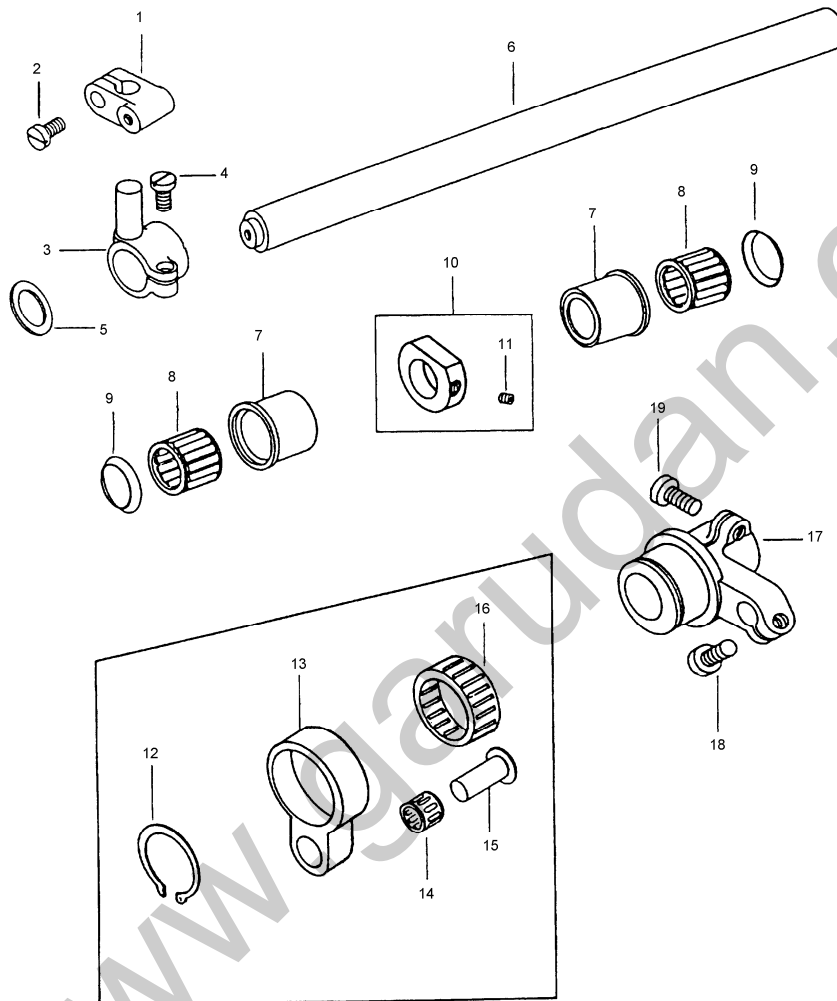

Ref.No.	Part No.	Name of Part	Q'ty
D1-1	GP/ 119164	Clamp	1
D1-2	GP/ 108177	Screw (M4x0,7x10)	1
D1-3	GP/ 119163	Crank	1
D1-4	GP/ 108225	Screw (M5x0,8x10)	1
D1-5	GP/ 119085	Washer	1
D1-6	GP/ 119511	Upper Side Shaft	1
D1-7	GP/ 118600	Bushing (23mm)	2
D1-8	GP/ 215124	Needle Bearing	2
D1-9	GP/ 133283	Washer	4
D1-10	GP/ 118504	Collar	1
D1-11	GP/ 700689	Screw (M6x0,75x4,5)	1
D1-12	GP/ 610370	Retaining Ring	1
D1-13	GP/ 119042-2	Eccentric With Rod	1
D1-14	GP/ 215028	Needle Bearing	1
D1-15	GP/ 175150	Pin	1
D1-16	GP/ 242810	Needle Bearing	1
D1-17	GP/ 119042	Crank With Eccentric	1
D1-18	GP/ 108225-2	Screw (M5x0,8x12)	1
D1-19	GP/ 130224	Screw (M5x0,8x12)	1

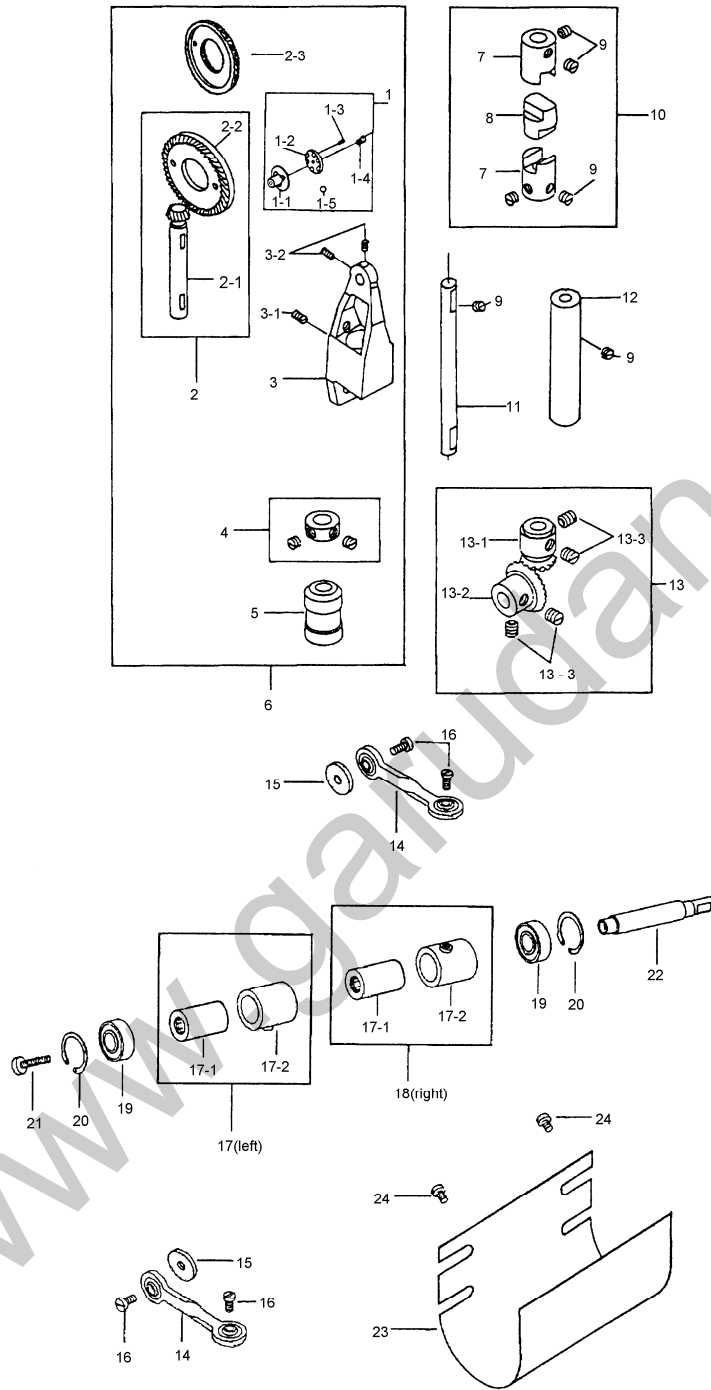



Ref.No.	Part No.	Name of Part	Q'ty
D2-1	GP/119795	Roller Bracket	1
D2-1-1	GP/119795-1	Roller Bracket	1
D2-1-2	GP/119795-2	Roller Bracket	1
D2-1-3	GP/119795-3	Screw	3
D2-1-4	GP/119795-4	Screw	3
D2-1-5	GP/119795-5	Ball d.2mm	23
D2-2	GP/119737	Bevel Gear	1
D2-2-1	GP/119737-1	Bevel Gear	1
D2-2-2	GP/119737-2	Bevel Gear	1
D2-2-3	GP/119737-3	Feed Wheel	1
D2-3	GP/119723	Bracket	1
D2-4	GP/119670	Collar	1
D2-5	GP/119724	Bushing	1
D2-6	GP/119723A	Bevel Gear Assy	1
D2-7	GP/119535	Bushing	2
D2-8	GP/119534	Clutch	1
D2-9	GP/119535-1	Screw (M5x08x4,5)	4
D2-10	GP/119535A	Clutch Assy	1
D2-11	GP/119532	Shaft	1
D2-12	GP/119533	Bushing	1
D2-13	GP/175113	Bevel Gear Assy	1
D2-13-1	GP/5045	Bevel Gear (Small)	1
D2-13-2	GP/5046	Bevel Gear (Medium)	1
D2-13-3	GP/700689	Screw (M6x0,75x4,5)	4
D2-14	GP/119507	Link	2
D2-15	GP/119087	Oil Felt	2
D2-16	GP/174176	Screw (M4x07x10)	4
D2-17	GP/119112	Free Wheeling (Left)	1
D2-17-1	GP/061014	Needle Bearing	2
D2-17-2	GP/119115-1	Free Wheeling Seat	2
D2-18	GP/119115	Free Wheeling (Right)	1
D2-19	GP/012555	Ball Bearing	2
D2-20	GP/664350	Retaining Ring 22mm	2
D2-21	GP/173174	Screw(M4x0,7x10)	1
D2-22	GP/119111	Shaft	1
D2-23	GP/119216	Cover/kryt	1
D2-24	GP/108174	Screw(M4x0,7x6) DIN 84A	4

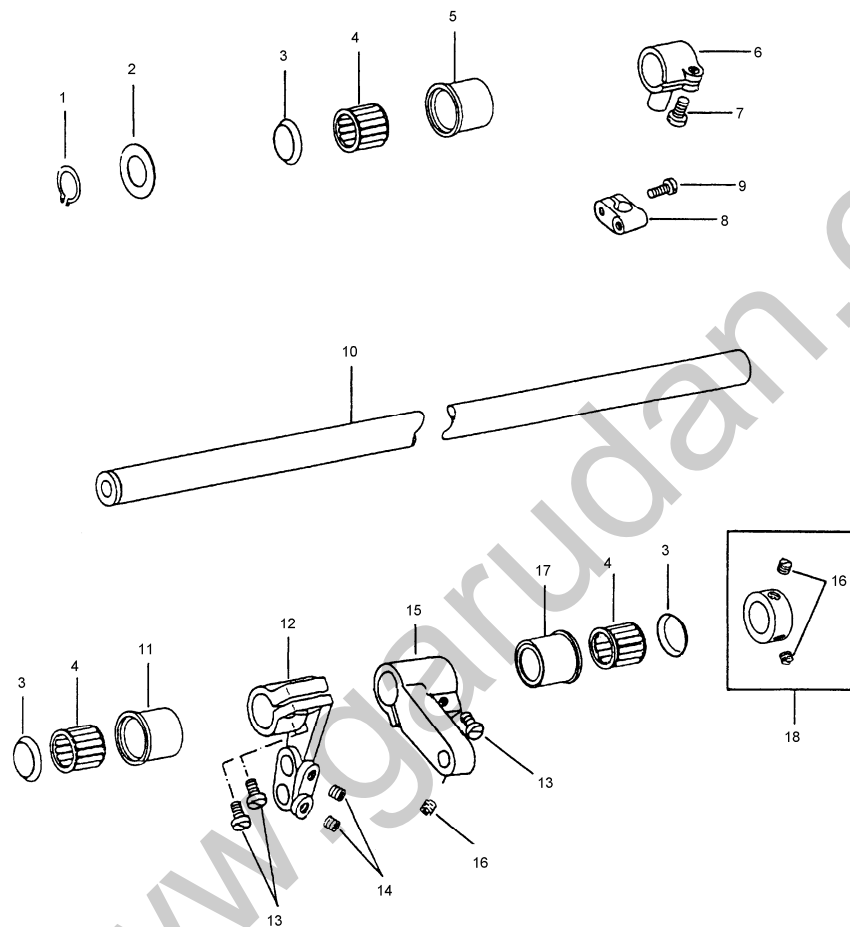

Ref.No.	Part No.	Name of Part	Q'ty
D3-1	GP/610280	Retaining Ring	1
D3-2	GP/119085	Washer	1
D3-3	GP/133283	Washer	6
D3-4	GP/215124	Needle Bearing	3
D3-5	GP/118600	Bushing	1
D3-6	GP/119163	Crank	1
D3-7	GP/108225	Screw (M5x0,8x10)	1
D3-8	GP/119164	Clamp	1
D3-9	GP/108177	Screw (M4x0,7x10)	1
D3-10	GP/119084	Shaft	1
D3-11	GP/118601	Bushing	1
D3-12	GP/119521	Crank	1
D3-13	GP/130224	Screw (M5x0,8x12)	4
D3-14	GP/335902-1	Screw (M6x0,75x8)	2
D3-15	GP/119521-1	Crank	1
D3-16	GP/700689	Screw (M6x0,75x4,5)	3
D3-17	GP/118603	Bushing	1
D3-18	GP/118893	Collar	1

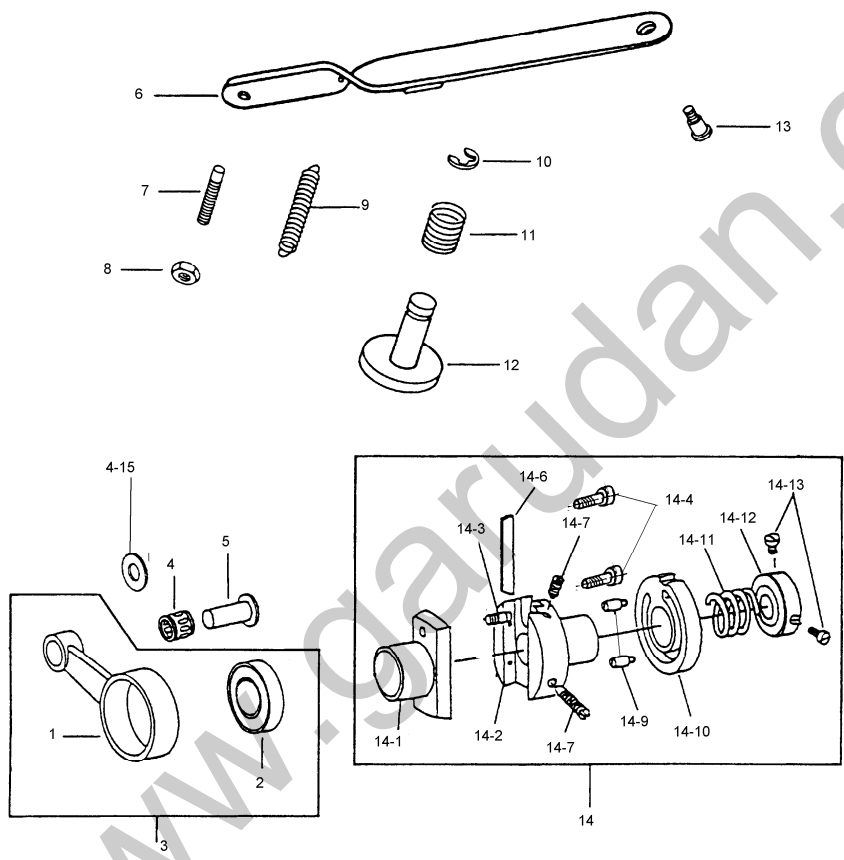

Ref.No.	Part No.	Name of Part	Q'ty
D4-1	GP/175038	Connecting Rod	1
D4-2	GP/069060	Ball Bearing	1
D4-3	GP/175038A	Crank Rod Set	1
D4-4	GP/215028	Needle Bearing	1
D4-5	GP/118612	Bearing Stud	1
D4-6	GP/165356	Feeding Adjusting Plate	1
D4-7	GP/165356-1	Screw (M5x0,8X20)	1
D4-8	GP/165356-8	Nut (M5x0,8x4)	1
D4-9	GP/165356-5	Spring	1
D4-10	GP/165356-7	E-Ring	1
D4-11	GP/165356-6	Spring	1
D4-12	GP/165356-2	Pin	1
D4-13	GP/165356-3	Screw (M6x1,0)	1
D4-14	GP/175029	Cam Assy	1
D4-14-1	GP/175029-1	Stitch Regulating Seat	1
D4-14-2	GP/175029-2	Stitch Regulating Fix Seat	1
D4-14-3	GP/175029-3	Feed Adjusting Screw	1
D4-14-4	GP/175029-4	Screw M3.5X8	2
D4-14-6	GP/175029-6	Friction Plate	1
D4-14-7	GP/175029-7	Screw (M6x0,75x10)	2
D4-14-9	GP/175029-9	Screw (11/64x40x2,5)	2
D4-14-10	GP/175029-10	Eccentric Wheel	1
D4-14-11	GP/175029-11	Spring	1
D4-14-12	GP/175029-12	Collar	1
D4-14-13	GP/175029-13	Screw (M4X8) DIN 912	2
D4-14-15	GP/169137	Washer 4x14x0.5 DIN 988	1

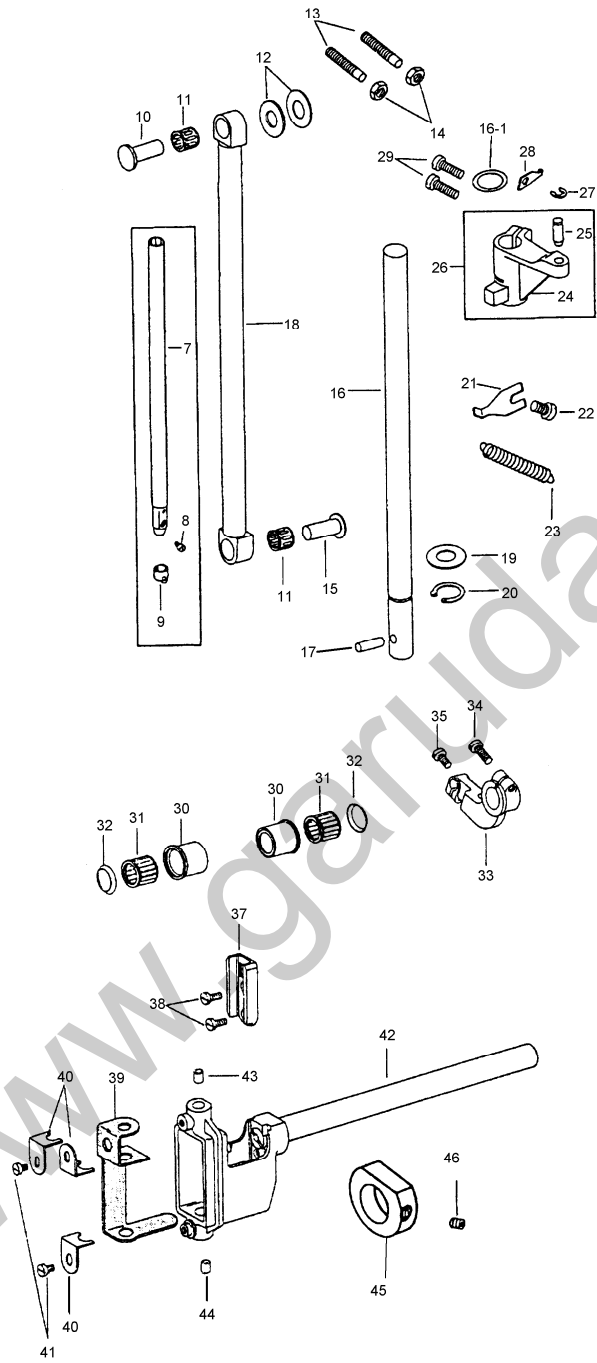

Ref.No.	Part No.	Name of Part	Q'ty
E-7	GP/175096	Needle Bar	1
E-8	GP/174173	Screw(M3x0,5x4)	1
E-9	GP/175096-2	Thread Guide	1
E-10	GP/175150	Pin	1
E-11	GP/215028	Needle Bearing	2
E-12	GP/169137	Washer (14x8,1x1mm)	2
E-13	GP/305305	Screw (M6x1,0x25)	2
E-14	GP/024191	Nut (M6x1,0x4,8)	2
E-15	GP/175150	Pin	1
E-16	GP/119718	Shaft (12x390)	1
E-16-1	GP/118545	Ewasher	1
E-17	GP/030310	Pin	1
E-18	GP/119046	Connecting Rod	1
E-19	GP/119525-2	Washer	1
E-20	GP/119718-2	Retaining Ring (12mm)	1
E-21	GP/118858	Spring Plate	1
E-22	GP/108285	Screw (M6x1,0x8)	1
E-23	GP/118857	Spring	1
E-24	GP/118543	Crank	1
E-25	GP/118544	Pin	1
E-26	GP/118543A	Crank Shaft	1
E-27	GP/640150	E-Ring	1
E-28	GP/020490	Spring Plate	2
E-29	GP/130224	Screw (M5x0,8x16)	2
E-30	GP/118600	Bushing	2
E-31	GP/215124	Needle Bearing	0
E-32	GP/133283	Washer	0
E-33	GP/118610	Crank	0
E-34	GP/108285-1	Screw (M6x1,0x1,4)	1
E-35	GP/130224	Screw (M5x0,8x12)	1
E-37	GP/118594	Needle Bar Connecting Link Guide	1
E-38	GP/100355	Screw (M4x0,7x6)	2
E-39	GP/119014	Oil Felt	1
E-40	GP/119015	Holder	3
E-41	GP/706169	Screw (M4x0,7x4,5)	2
E-42	GP/119940	Needle Bar Holder	1
E-43	GP/119940-5	Needle Bar Bushing	1
E-44	GP/119940-4	Needle Bar Bushing	1
E-45	GP/118504	Collar	1
E-46	GP/700689	Screw M6x0.75x4.5	1

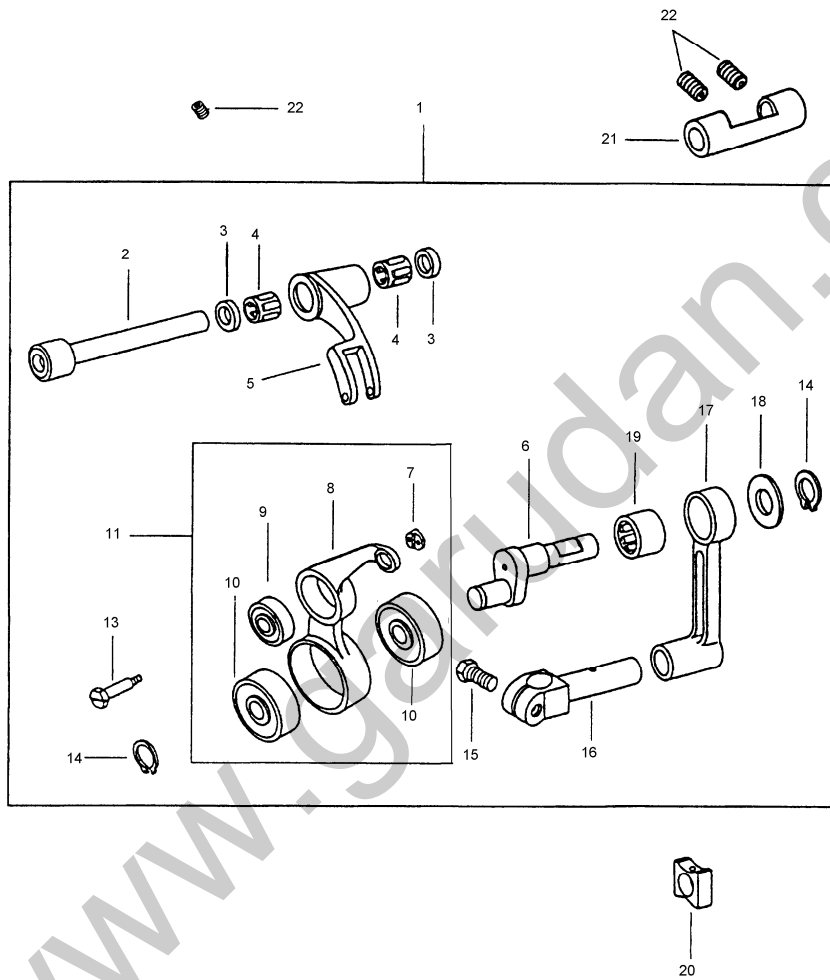



Ref.No.	Part No.	Name of Part	Q'ty
		500-149	
F-1	GP/118084	Thread Take-up Assy	1
F-2	GP/119009	Take-up Lever Support Stud	1
F-3	GP/168039	Washer	2
F-4	GP/215022	Needle Bearing	2
F-5	GP/119008	Take-up Frame	1
F-6	GP/119762	Take-up Crank Pin	1
F-7	GP/119049	Bushing	1
F-8	GP/119007	Take-up Lever	1
F-9	GP/167569	Ball Bearing	1
F-10	GP/167570	Ball Bearing	2
F-11	GP/119006	Take-up Lever	1
F-13	GP/168047	Screw (M4x0,7x13,5)	1
F-14	GP/610210	Retaining Ring	2
F-15	GP/039177	Screw (M4x0,7x12,5)	1
F-16	GP/119013	Needle Bar Connecting Stud	1
F-17	GP/119765	Needle Bar Connecting Crank Rod	1
F-18	GP/119763	Washer	1
F-19	GP/218080	Needle Bearing	1
F-20	GP/118518	Needle Bar Guide Slide Block	1
F-21	GP/168041	Bushing	1
F-22	GP/314220	Screw (M5x0,8x8)	3

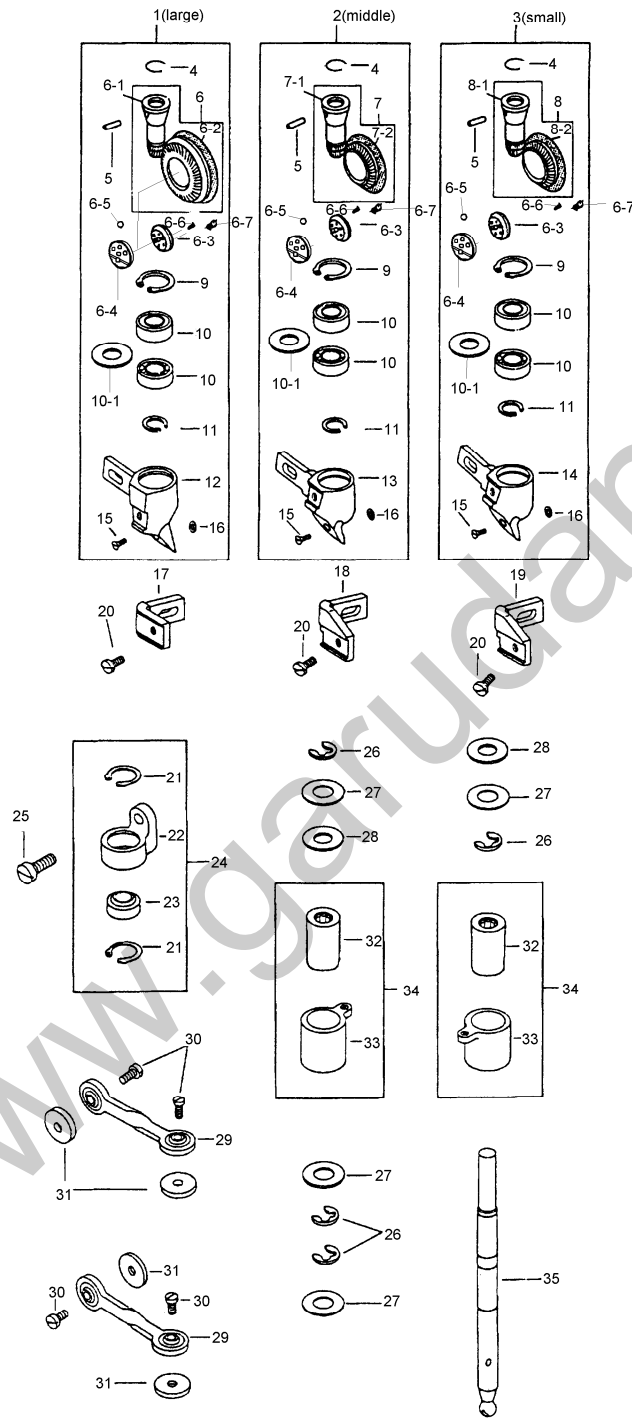

Ref.No.	Part No.	Name of Part	Q'ty
G1-1	GP/119803	Roller Preser Assy (Large)	1
G1-2	GP/119803-1	Roller Preser Assy (Middle)	1
G1-3	GP/119802	Roller Preser Assy (Small)	2
G1-4	GP/119469	Spring Washer	2
G1-5	GP/033145	Pin	1
G1-6	GP/175109	Gear	1
G1-6-1	GP/175109-1	Gear Presser Shaft	1
G1-6-2	GP/175109-2	Gear	1
G1-6-3	GP/175109-3	Roller Bracket	1
G1-6-4	GP/175109-4	Roller Bracket	1
G1-6-5	GP/175109-5	Ball d.2mm	20
G1-6-6	GP/175109-6	Screw	3
G1-6-7	GP/175109-7	Screw	3
G1-7	GP/175107	Gear	1
G1-7-1	GP/175107-1	Gear Presser Shaft	2
G1-7-2	GP/175107-2	Gear	1
G1-8	GP/175108	Gear	1
G1-8-1	GP/175108-1	Gear Presser Shaft	1
G1-8-2	GP/175108-2	Gear	2
G1-9	GP/664290	Retaining Ring	1
G1-10	GP/133116	Ball Bearing	2
G1-10-1	GP/133116-1	Washer	1
G1-11	GP/518210	Retaining Ring	1
G1-12	GP/119953	Roller Presser Bracket	1
G1-13	GP/119943	Roller Presser Bracket	1
G1-14	GP/119956	Roller Presser Bracket	1
G1-15	GP/210043	Screw (M2,5x0,45x6)	1
G1-16	GP/119491	Washer	1
G1-17	GP/119807	Guide Seat	1
G1-18	GP/119955	Guide Seat	1
G1-19	GP/119954	Guide Seat	1
G1-20	GP/173174	Screw (M4x0,7x8)	1
G1-21	GP/660290	Retaining Ring (16mm)	2
G1-22	GP/119158	Bearing Bracket	1
G1-23	GP/756901	Bearing	1
G1-24	GP/119150	Bearing Set	1
G1-25	GP/108294	Screw (M6x1x13)	1
G1-26	GP/640210	E-Ring (8mm)	4
G1-27	GP/119159	Washer (20x9,65x1mm)	2
G1-27-1	GP/119160	Washer(20x9,65x1,4mm)	2
G1-28	GP/119886	Washer(20x9,65x0,1mm)	2
G1-28-1	GP/119961	Washer(20x9,65x0,15mm)	2
G1-28-2	GP/119962	Washer(20x9,65x0,2mm)	2
G1-28-3	GP/119963	Washer(20x9,65x0,05)	2
G1-29	GP/119507	Link	2
G1-30	GP/174176	Screw(M4x0,7x10)	4
G1-31	GP/119087	Oil Felt	4
G1-32	GP/61014	Needle Bearing	2
G1-33	GP/119505	Free - Whealing	2
G1-34	GP/119506	Bearing Set	2
G1-35	GP/119503	Shaft	1

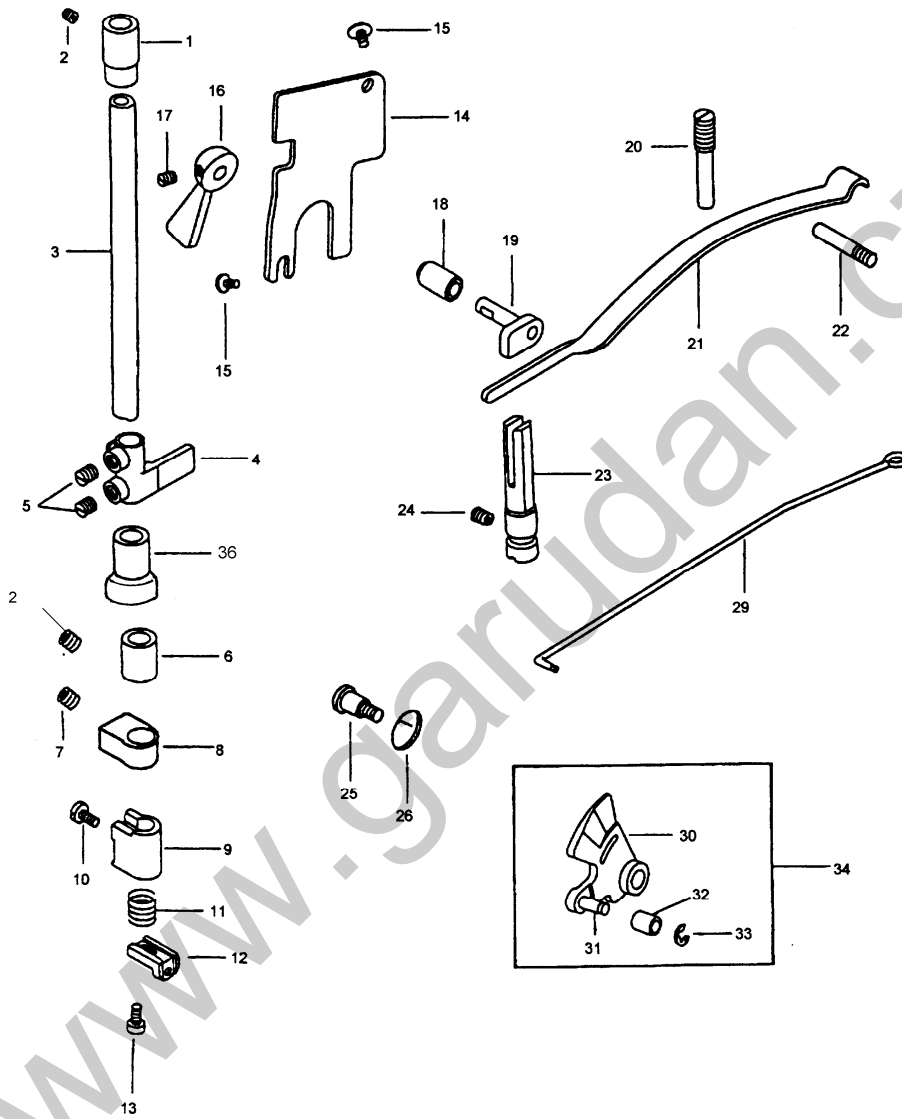

Ref.No.	Part No.	Name of Part	Q'ty
G2-1	GP/119019	Presser Bar Bushing (Upper)	1
G2-2	GP/700785	Screw (M5x0,8x6)	2
G2-3	GP/119018	Presser Bar Bushing (Upper)	1
G2-4	GP/118530	Presser Bar Holder	1
G2-5	GP/700510	Screw (M6x0,75x8)	2
G2-6	GP/119019-1	Presser Bar Bushing (Lower)	1
G2-7	GP/700510-1	Screw (M6x1,0x8)	1
G2-8	GP/119165-1	Roller Presser Holder	1
G2-9	GP/119165	Roller Presser Holder	1
G2-10	GP/173174	Screw (M4x0,7x8)	1
G2-11	GP/025874	Spring	1
G2-12	GP/054876	Angle	1
G2-13	GP/130173	Screw (M4x0,7x9)	1
G2-14	GP/175135	Cover	1
G2-15	GP/700335	Screw (M5x0,8x7)	2
G2-16	GP/069079	Presser Foot Lifter	1
G2-17	GP/317950	Screw (M5x0,8x6)	1
G2-18	GP/119004	Bushing	1
G2-19	GP/118577	Cam Shaft	1
G2-20	GP/100331	Screw (M8x0,75)	1
G2-21	GP/118535	Presser Plate Spring	1
G2-22	GP/343901	Screw (M6x1,0)	1
G2-23	GP/118105	Stud	1
G2-24	GP/314286	Screw (M6x1,0x8)	1
G2-25	GP/700017	Screw (M6x1,0)	1
G2-26	GP/119016	Spring	1
G2-29	GP/118542	Knee Lifter Connecting Lever	1
G2-30	GP/118536	Spring Plate	1
G2-31	GP/118536-1	Pin	1
G2-32	GP/118539	Bushing	1
G2-33	GP/640150	E-Ring	1
G2-34	GP/118536A	Lifting Lever Assy	1
G2-36	GP/400-MG	Support/opěra	1

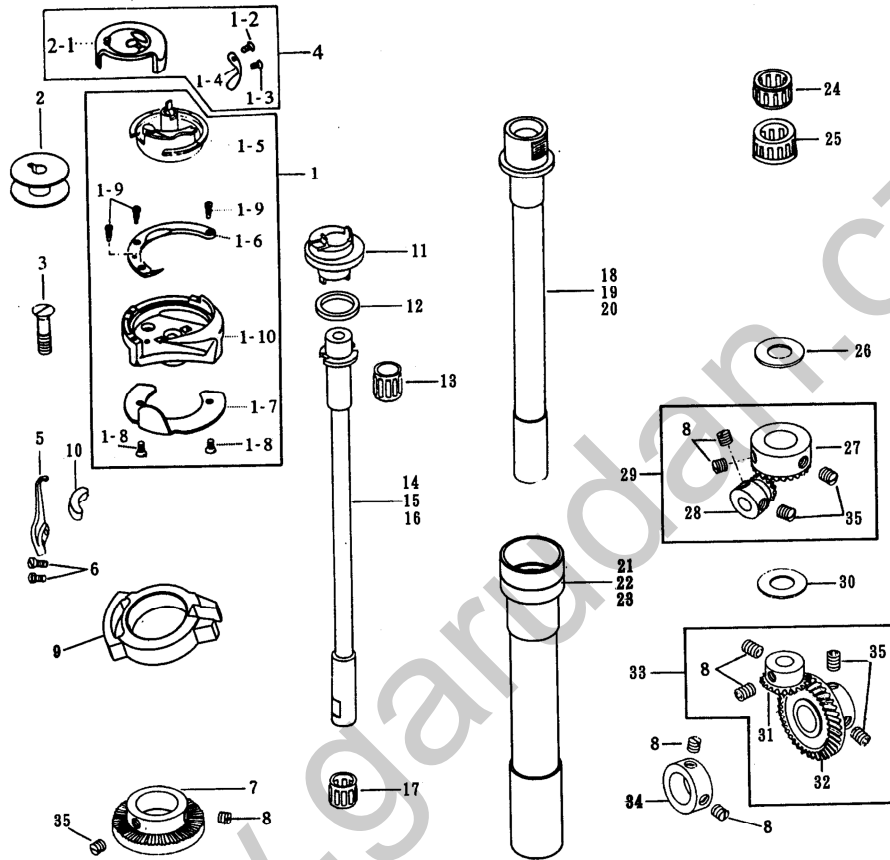

Ref.No.	Part No.	Name of Part	Q'ty		
			518	528	538
H1-1+4	GP/119716A-S	Hook assy	1	1	1
H1-1-2	GP/000390	Screw	2	2	2
H1-1-3	GP/000928	Screw	1	1	1
H1-1-4	GP/010166	Spring	1	1	1
H1-1-5	GP/119487	B/C base	1	1	1
H1-1-6	GP/175136	Hook gib	1	1	1
H1-1-7	GP/119377	Needle guard washer	1	1	1
H1-1-8	GP/000219	Screw	2	2	2
H1-1-9	GP/100529	Screw	2	2	2
H1-1-10	GP/119376	Hook	1	1	1
H1-2	GP/270010QWS	Bobbin	1	1	1
H1-2-1	GP/010158	Bobbin case	1	1	1
H1-3	GP/100205	Screw	2	2	2
H1-4	GP/119716-S	Bobbin case assy	1	1	1
H1-5	GP/119129	Rotating hook opener	1	1	1
H1-6	GP/108093	Screw	2	2	2
H1-7	GP/119148	Driving wheel	1	1	1
H1-8	GP/700872	Screw	7	7	7
H1-9	GP/119127	Rotating hook opener bracket	1	1	1
H1-10	GP/119128	Oil felt	1	1	1
H1-11	GP/119525-1	Hook driver	1	1	1
H1-12	GP/119105	Washer	1	1	1
H1-13	GP/215031	Needle bearing	1	1	1
H1-14	GP/119525-R	Hook shaft	1	-	-
H1-15	GP/119525-1-R	Hook shaft	-	1	-
H1-16	GP/119525-2-R	Hook shaft	-	-	1
H1-17	GP/215028	Needle bearing	1	1	1
H1-18	GP/119524-R	Feed wheel shaft (180)	1	-	-
H1-19	GP/119524-1-R	Feed wheel shaft (280)	-	1	-
H1-20	GP/119524-2-R	Feed wheel shaft (380)	-	-	1
H1-21	GP/119979-R	Feed wheel shaft (180)	1	-	-
H1-22	GP/119979-1-R	Feed wheel shaft (280)	-	1	-
H1-23	GP/119979-2-R	Feed wheel shaft (380)	-	-	1
H1-24	GP/215030	Needle bearing	1	1	1
H1-25	GP/215029	Needle bearing	1	1	1
H1-26	GP/125010	Washer	1	1	1
H1-27	GP/119134-1	Bevel gear (large)	1	1	1
H1-28	GP/119134-2	Bevel gear (small)	1	1	1
H1-29	GP/119134	Bevel gear assy	1	1	1
H1-30	GP/125010	Washer	1	1	1
H1-31	GP/119133-1	Bevel gear (large)	1	1	1
H1-32	GP/119133-2	Bevel gear (small)	1	1	1
H1-33	GP/119133	Gear set	1	1	1
H1-34	GP/123778	Collar	1	1	1
H1-35	GP/341901-1	Screw	5	5	5

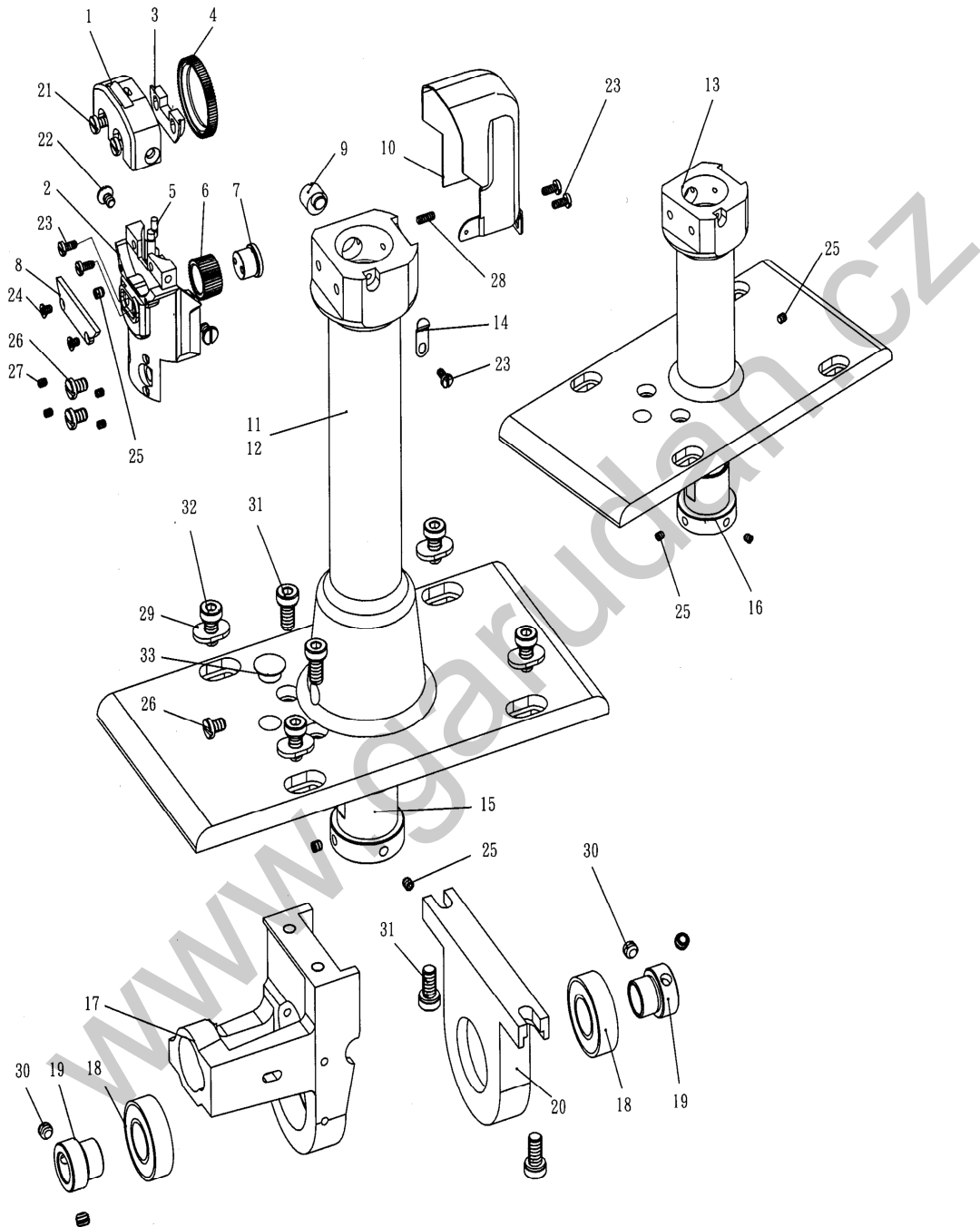



Ref.No.	Part No.	Name of Part	Q'ty		
			518	528	538
I1-1	GP/015001	Needle plate	1	1	1
I1-2	GP/015002	Needle plate seat	1	1	1
I1-3	GP/015003	Bearing plate	1	1	1
I1-4	GP/015004	Feed wheel	1	1	1
I1-5	GP/015005	Stud	1	1	1
I1-6	GP/015006	Bevel gear	1	1	1
I1-7	GP/015007	Pin	1	1	1
I1-8	GP/015008	Cover plate	1	1	1
I1-9	GP/015009	Stud	1	1	1
I1-10	GP/015010	Post cap assy	1	1	1
I1-11	GP/015011-R	Hook bracket (380)	-	-	1
I1-12	GP/015012-R	Hook bracket (280)	-	1	-
I1-13	GP/015012-R	Hook bracket (180)	1	-	-
I1-14	GP/015014	Spring plate	1	1	1
I1-15	GP/015015	Bushing	-	1	1
I1-16	GP/015016	Bushing	1	-	-
I1-17	GP/015017	Side bracket (left)	1	1	1
18	GP/015018	Bearing	2	2	2
19	GP/ 015019	Collar	2	2	2
20	GP/015020	Side bracket (right)	1	1	1
21	GP/ 015021	Screw	2	2	2
22	GP/015022	Screw	2	2	2
23	GP/015023	Screw	5	5	5
24	GP/015024	Screw	2	2	2
25	GP/015025	Screw	4	3	3
26	GP/015026	Screw	2	3	3
27	GP/015027	Screw	4	4	4
28	GP/015028	Screw	1	1	1
29	GP/015029	Screw	4	4	4
30	GP/015030	Screw	4	4	4
31	GP/015031	Screw	4	4	4
32	GP/015032	Screw	4	4	4
33	GP/ 015032	Screw	1	1	1

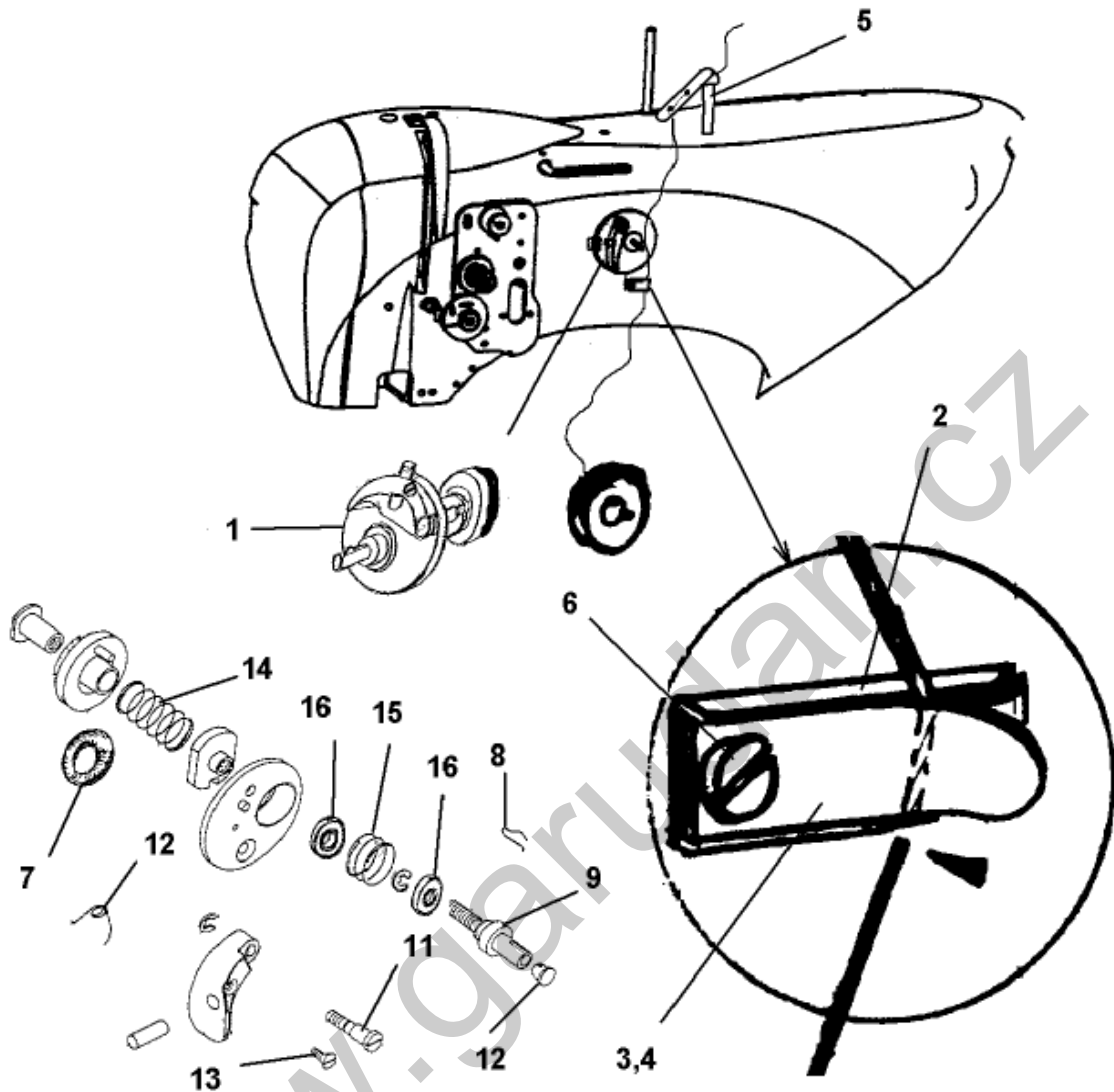

Ref. No.	Part No.	Name of Part	Q'ty
N1-1	GP/GU-100T	Bobbin Winder-Built in	1
N1-2	D/D08082993000	Knife	1
N1-3	D/D08028312900	Spring 283129	1
N1-4	D/D08028313000	Spring 283130	1
N1-5	P/P98002524800	Thread Retainer	1
N1-6	GP/M3x5	Screw M3x5 DIN 84A	1
N1-7	GP/941048-1	O Ring 14x6	1
N1-8	GP/GU-100-024T	Spring	1
N1-9	GP/GU-100-020T	Pin	1
N1-10	GP/GU-100-026T	Plug	1
N1-11	GP/GU-100-025T	Screw	1
N1-12	GP/GU-100-023T	Spring	1
N1-13	GP/M4X10	Screw M4x10 DIN 963A	1
N1-14	GP/GU-100-018T	Spring	1
N1-15	GP/GU-100-019T	Spring	1
N1-16	GP/	Ball Bearing	2

[www.garudan.cz](http://www.garudan.cz)

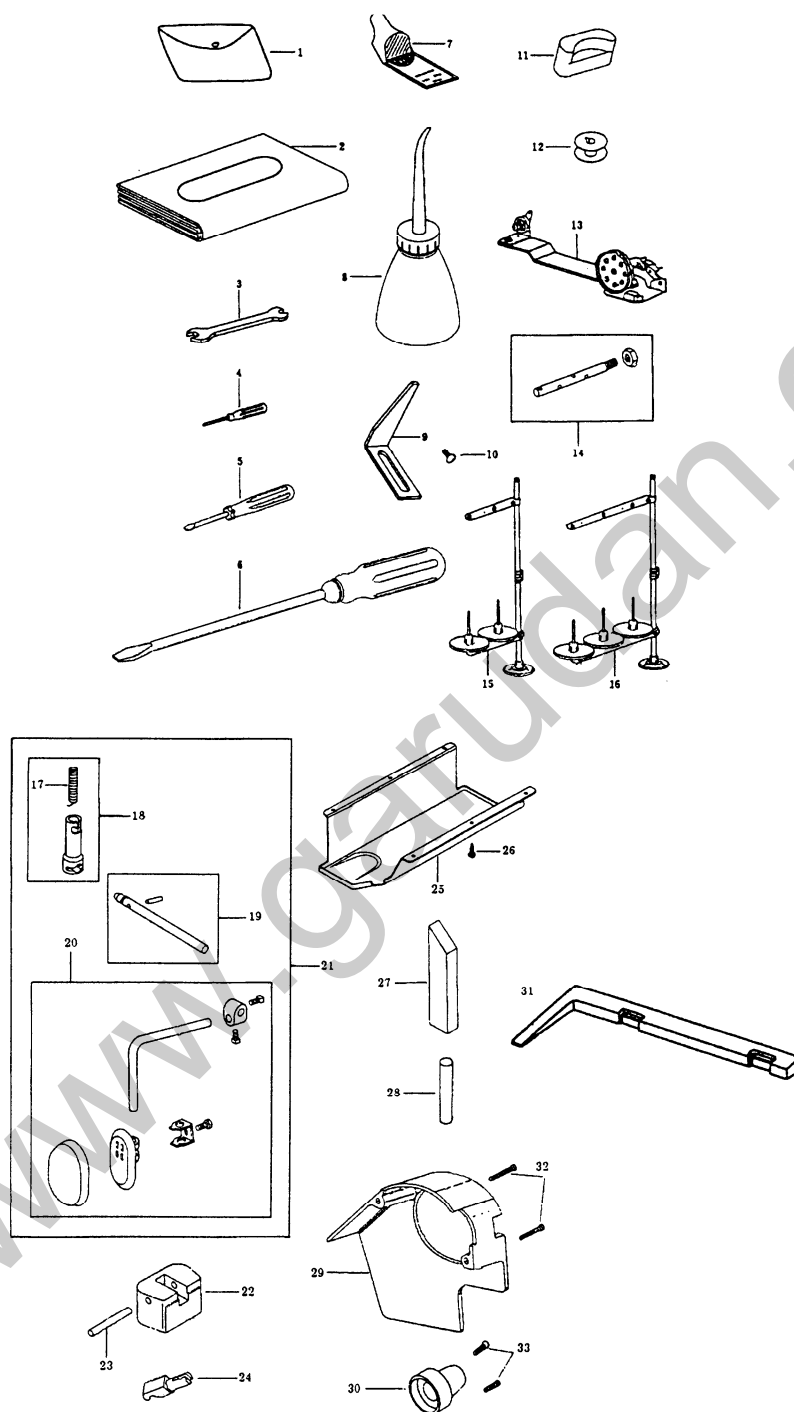

Ref.No.	Part No.	Name of Part	Q'ty
N2-1	GP/123456	Accessory Bag	1
N2-2	GP/029836	Vinyl Cover	1
N2-3	GP/800110	Spanner	1
N2-4	GP/129915	Screw Driver (Small)	1
N2-5	GP/029946	Screw Driver (Middle)	1
N2-6	GP/029007	Screw Driver (Large)	1
N2-7	GP/134LR	Needle	10
N2-8	GP/029394	Oiler	1
N2-9	GP/119089-1	Stitching Length Indicator	1
N2-10	GP/100355	Screw	1
N2-11	GP/032808	Head Cushion	2
N2-12	GP/270010QWS	Bobbin	4
N2-14	GP/119026	Spool Pin	1
N2-15	GP/FPL2	Thread Stand (2-Pole)	0
N2-16	GP/FPL3	Thread Stand (3-Pole)	1
N2-17	GP/171543	Spring	1
N2-18	GP/171542	Knee Lever Coupling	1
N2-19	GP/171413	Knee Lever Rod	1
N2-20	GP/171412	Knee Lever Assy	1
N2-21	GP/171411	Knee Lever Rod Assy	1
N2-22	GP/029934	Hinge Connection Seat	2
N2-23	GP/030341	Pin	2
N2-24	GP/029450	Hinge Pin	2
N2-25	GP/118636	Oil Pan	1
N2-26	GP/460157	Screw	6
N2-27	GP/032717	Head Rest Wood	1
N2-28	GP/032717-1	Housing Support Stud	1
N2-29	GP/119078	Belt Cover Set (Large)	1
N2-30	GP/119088	Belt Cover Set (Small)	1
N2-31	GP/119999	Wedge	1
N2-32	GP/119089-2	Screw	2
N2-33	GP/119078-1	Screw	2

[www.garudan.cz](http://www.garudan.cz)