

User's Manual  
and Spare Parts Book

**GARUDAN**®

**GF-1117-447 H**



ANITA B, s.r.o.

Průmyslová 2453/7

680 01 Boskovice

Czech Republic

tel: +420 516 454 774

+420 516 453 496

fax: +420 516 452 751

e-mail: [info@anita.cz](mailto:info@anita.cz)

[www.garudan.cz](http://www.garudan.cz)

All rights reserved.

Property of Anita B s.r.o. and protected by copyright. The use of this content without written permission is prohibited.

Copyright © Anita B s r.o. (2016)

## **CONTENTS**

	Page no.
<b>1) Technical Specification</b>	4
<b>2) Safety precautions</b>	5
<b>3) Installation</b>	7
3.1 Before Use	7
3.2 Machine head	8
3.3 Chip discharge plate	8
3.4 Resistance box for knee-lifting solenoid	9
3.5 Lubrication	9
3.6. Belt tension adjustment	10
3.7. Program unit	10
3.8 Belt cover	11
3.9 Location detector assembly and adjustment	12
3.10 Location adjustment of location detector	12
3.11 Check for stop position of sewing machine	13
3.12 Back tack button	13
<b>4) Control and Adjustment of the machine</b>	14
4.1 Needle insertion	14
4.2 Needle bar adjustment	14
4.3 Timing adjustment of needle and hook	15
4.4 Lubrication adjustment of thread take-up lever	15
4.5 Lubrication adjustment of hook	16
4.6 Inserting lower thread and tension adjustment	17
4.7 Routing upper thread	17
4.8 Upper thread adjustment	18
4.9 Height and tension adjustment of presser foot	19
4.10 Adjustment of automatic knee-lifter	20
4.11 Stitch length adjustment	20
4.12 Height and inclination adjustment of feed dog	20
4.13 Feed cam adjustment	21
4.14 Adjustment of needle movement	23
4.15 Timing adjustment of trimmer	23
4.16 Tension adjustment of fixed blade	24
4.17 Replacement of movable knife	25
4.18 Replacement of fixed blade	25
4.19 Adjustment of bobbin catcher	25
4.20 Wiper adjustment	26
4.21 Knife adjustment	27
4.22 Use of chip discharge guide and auxiliary needle plate	28
4.23 Change of cutting width	28
<b>5) Cause of troubles and troubleshooting</b>	
5.1 Sewing machine troubleshooting	30

## 1) TECHNICAL SPECIFICATION

Model	Usage	Max speed	Max stitch length	Needle system & size	Presser foot (manual/knee)
GF-1116-143 LM	light-medium	4.500	5mm	134R(70-110)	4/10mm
GF-1116-147 LM	light-medium	4.500	5mm	134R(70-110)	4/10mm
GF-1117-143 MH	medium-heavy	3.500	5mm	134R(100-130)	5.5/13mm
GF-1117-443 H	heavy	3.000	5mm	134R(110-160)	5.5/13mm
GF-1117-447 H	heavy	3.000	5mm	134R(110-160)	5.5/13mm
GF-1118-143 LM	light-medium	4.500	5mm	134R(70-110)	4/10mm
GF-1118-147 LM	light-medium	4.500	5mm	134R(70-110)	4/10mm

### General description and usage:

GF- 1116 series - single needle high-speed industrial sewing machines with lower drop feed.  
 GF-1117,1118 series - single needle high-speed industrial sewing machines with needle feed.  
 The characteristic feature is pressure lubrication. Machines are designed for sewing clothes and garments.

## 2) SAFETY PRECAUTIONS

Safety labels in the manual are categorized into danger, warning and caution.  
Failure to follow the safety rules may result in physical injuries or mechanical damages.  
The safety labels and symbols are defined as follows.

[The meaning of the safety marks]

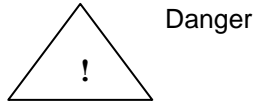

Danger

Instructions here shall be observed strictly.  
Otherwise, the user will be killed or suffer severe physical injuries.

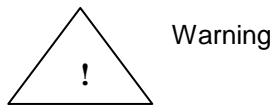

Warning

Instructions here must be observed, or the user could suffer fatal or severe physical injuries.



Caution

Instructions here should be observed, or the user could face physical injuries or mechanical damages.

[The meaning of the safety marks]



This mark means a 'must-not.'



This mark means a 'must' for safety.



This mark means that an electric shock may be caused if the instruction is not followed properly.

**1-1) Machine mobilization:** Only personnel with a full understanding of the safety rules should move the machines. The following directions must be observed when delivering the machines.



Danger

- a. At least two or more people should move the machine.
- b. Before delivering the machine, thoroughly wipe off the oil on the machine to prevent accidents.

**1-2) Machine installation:** Physical damages such as functional difficulties or breakdowns may occur depending on installation conditions of the machines. Be sure to heed the following conditions.



Caution

- a. Remove the packing from top to bottom.
- b. Install a climate controller and clean it regularly to prevent dust and moisture build-up from contaminating and corroding the

machines.

- c. Keep the machines away from direct sunlight.
- d. Keep a minimum distance of 50cm between the machine at both sides and backside and the wall to secure sufficient space for repair.
- e. Do not operate the machine near areas with danger of explosion. Refrain from running the machine in the vicinity of risky places, e.g., where a large quantity of aerosol-spraying products or oxygen are handled, unless specific quarantees are given otherwise for the operation of the machine to prevent explosion at such places.
- f. The user should install an illuminator in the work area for the machine not come supplied with any lighting apparatus due to the specific features of the machine.

[Note] Details of the machine installation are laid out in section 3) Installation.

**1-3) Troubleshooting:** When the machine is in need of repair, only our authorized service technicians must handle it.



Danger

- a. Before cleaning and repairing the machine, shut off the power supply and wait four minutes for the machine to discharge completely.
- b. No part of the machine or specifications may be modified without prior consultation with our company. Any such modification could risk safe operation of the machine.
- c. In case of repair, replace only with original Garudan parts from Anita.
- d. After repair, put safety covers back on the machine.

**1-4) Machine operation:** Machines are intended to be used for industrial purposes for sewing textiles and other similar materials. Carefully study the following instructions before operating the machine.



Caution

- a. Read the manual thoroughly and understand the instructions fully before use.
- b. Put on proper safety garments.
- c. While the machine is in motion, keep your hands or any part of your body away from moving parts, e.g., needle, hook, thread take-up spring and pulley, etc.
- d. Do not remove any form of safety covers while the machine is in use.
- e. Be sure to connect the ground (earth) wire.
- f. Before opening electric boxes such as the control box, shut down the power supply and make sure the power switch is in "off" mode.
- g. Stop the machine before threading the needle or checking after sewing work is finished.
- h. Never turn the power switch on with the pedal down.
- i. Do not use the machine if the cooling fan is clogged. Clean the air filter embedded in the control box at least once a week.
- j. Keep the machine away from strong electromagnetic fields such as high-frequency welding machines.



Caution

**Always start the machine with safety covers in place since fingers or hands could be injured or cut off by the belt. Turn off the power switch when conducting a regular check on the machine.**

**1-5) Safety device:**



Caution

- a. Safety label: Safety instructions for machine operations
- b. Thread take-up spring cover: A device designed to prevent the human body from coming in contact with the thread take-up spring
- c. Belt cover: A device intended to avoid potential risks of getting hands, feet or clothes jammed by the belt
- d. Finger guard: A device built to keep fingers away from the needle

### 3) INSTALLATION



#### Warning

- ⇒ The machine must be installed by a trained technician only.
- ⇒ Any electrical wiring must be performed by a qualified technician or agent.
- ⇒ The machines weigh over 33 kg. As such, two or more people should carry out the installation.
- ⇒ Plug in only after the installation is complete. If the operator mistakenly steps down on the pedal with the plug in, the machine will start automatically and can cause physical injuries.
- ⇒ Connect the ground (earth) wire.  
An unstable connection may result in an electric shock or a malfunction.
- ⇒ Use both hands when bending the machine backward or returning it to the normal position.  
Using only one hand can lead to physical injuries due to the weight of the machine.

#### 3.1) Before Use

- A: Motor must not be switched on while the pedal is in pressure
- B: When you finish operation, always turn off the main switch
- C: During any adjustment, repair or needle xchange make sure that the machine is turned off
- D: Make sure that ground connection is properly installed
- E: Dont use too many connections on one source
- F: Keep safety distance from sources of noise
- G: Before manipulation with motor, wait several minutes after being switched off
- H: If system error is detected, indentify type of error, remove it and then switch on the machine
- I: Check carefully proper connection of all connectors and cables
- J: Check tension of V-belt according to instructions
- K: During installation of new machine or machine which has not been used for long time, apply repeatedly oil on indicated places of thread take up lever, presser bar and needle bar (Fig 0)
- L: Keep machine going for about 10 minutes at speed 3.000 spm to test it, checking the oil level
- M: After initial testing of the machine, set the speed lower than 3.000 spm for the first 4-5 days.

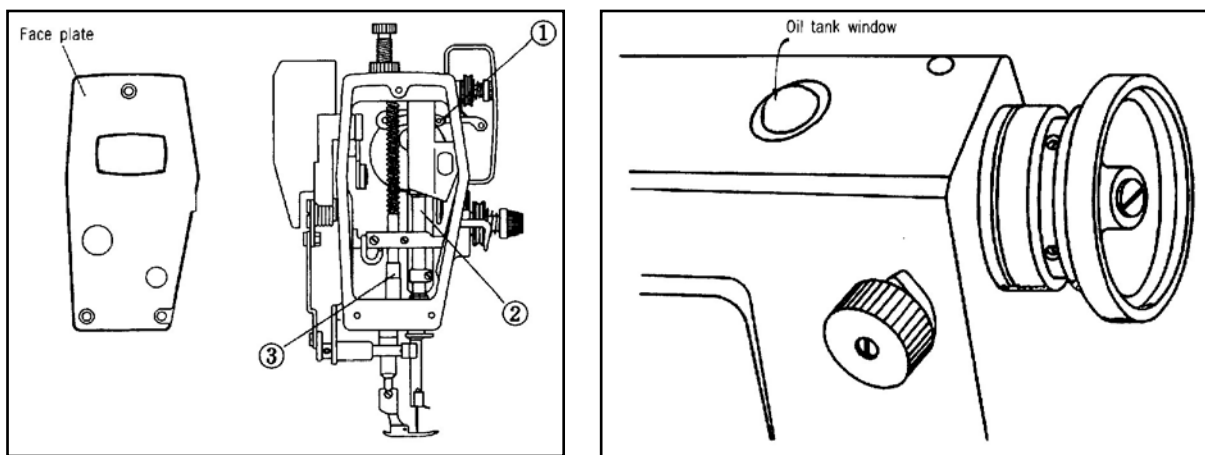

(Fig. 0)

### 3.2) Machine head

Insert the head hinge (1) into the bed holes and fit it to the rubber hinge (2). Then stand it on the rubber cushions (3) in the four corners. (See Fig.1)

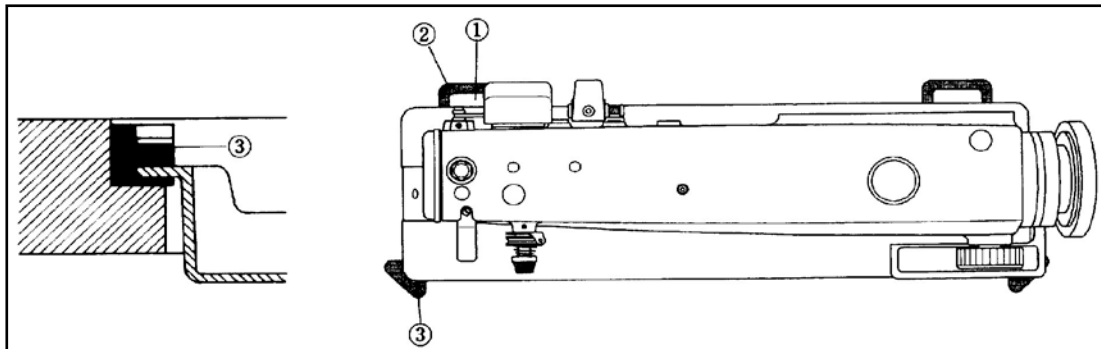

(Fig. 1)

### 3.3) Chip discharge plate (GF-1116/1118 serie)

Use the chip discharge plate installation guidelines included in the accessory box to attach the plate to the bottom of the table as in the figure. (See Fig.2)

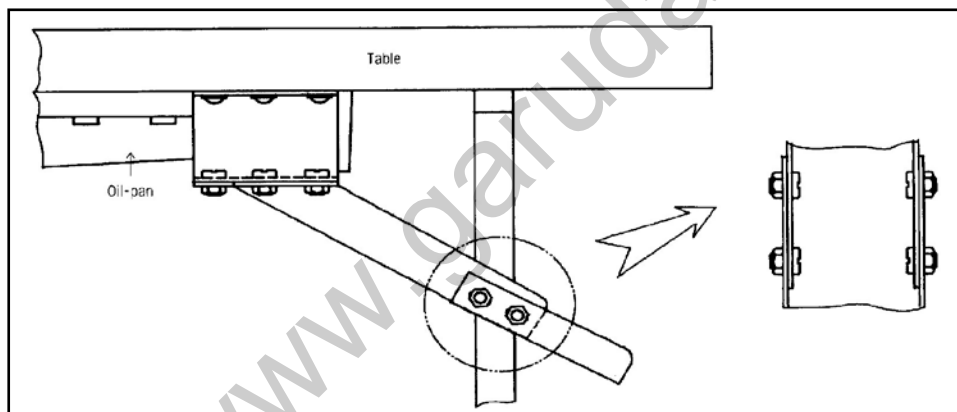

(Fig. 2)



### 3.4) Resistance box for knee-lifting solenoid

Installation:

- a) Attach the resistance box around the motor under the table.
- b) Connect the connector from the solenoid to the resistance box as shown in Fig. 3, and then connect the line from the resistance box to the control box.

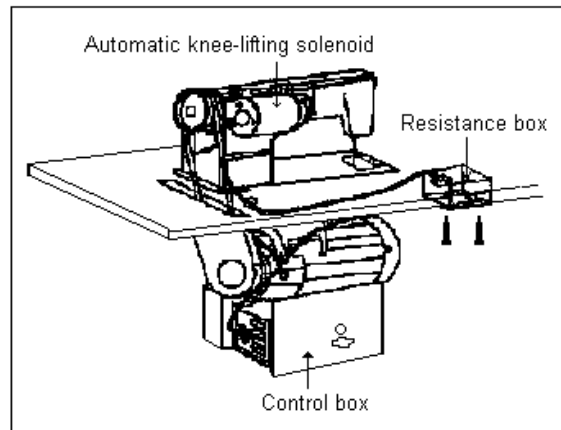

(Fig. 3)



### Caution

- ▶ Plug in only after oil supply is finished. If the operator mistakenly steps on the pedal with the plug in, the machine will start automatically and can cause severe injuries.
- ▶ When handling lubricants, wear protective glasses or gloves to avoid contact with your eyes or skin. Inflammation may be caused otherwise. Never drink lubricants since they can cause vomiting or diarrhea. Keep out of the reach of children.
- ▶ Operate the machine only after adding oil when the machine is being used for the first time or has been left unused for a long time.

### 3.5) Lubrication

#### 1. Installing Magnetic Chip Remover

A. Attach the magnetic chip remover that is in the accessory box to the oil pump inside the bed.

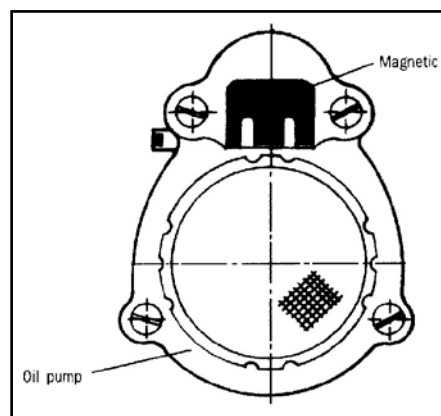

(Fig. 4)

- ▶ Do not use the magnet for other purposes. Use of the sewing machine without the magnet may cause malfunction and has a bearing on the machine's durability.

#### 2. Lubricating the oil fan

- A. Fill the lubricant up to the "HIGH" mark. (See Fig. 5)
- B. The lubricant must be Garudan's oil provided exclusively for industrial sewing machines or SHELL's Tellus C10.
- C. If the oil in use is down to the "LOW" mark, fill in to "HIGH" immediately.
- D. Once every two weeks is deemed the appropriate interval for oil refills.

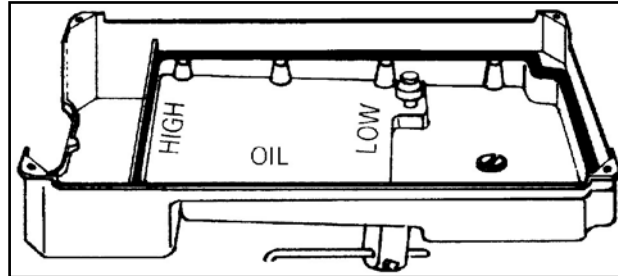

(Fig.5)

### 3.6) Belt Tension Adjustment

Sufficient loosening of the fixed nuts (1), (2) after motor (3) installation would create tension to the belt (4). Tighten the fixed nut (1) first and then tighten the fixed nut (2) to an unmovable position. (See Fig. 6)

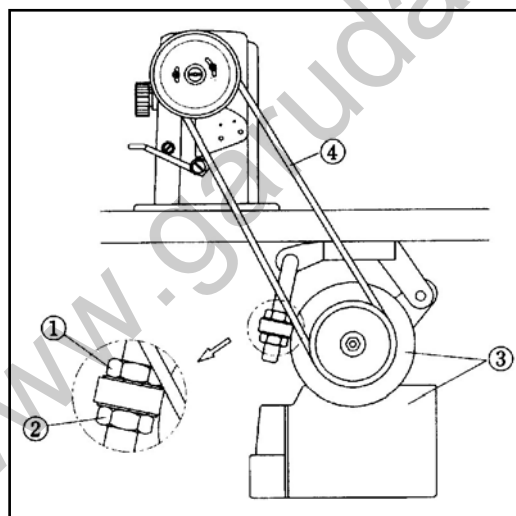

(Fig.6)

### 3.7) Program Unit

- A. Installing automatic knee-lifting solenoid on machine head  
Use five fixing screws (4) to attach the solenoid on the back side of machine head. (See Fig. 7)
- B. Assembling of back cover  
When the machine is equipped by manual knee-lifter, fasten the bracket tightly using the three fixing screws in the back lid of the machine. (See Fig. 8)
- C. Assembling of control panel  
Use four fixing screws to fix the bracket (2) onto the control panel. Using the two screws (4) to attach the assembly on the top of machine head. (See Fig. 7, 8)

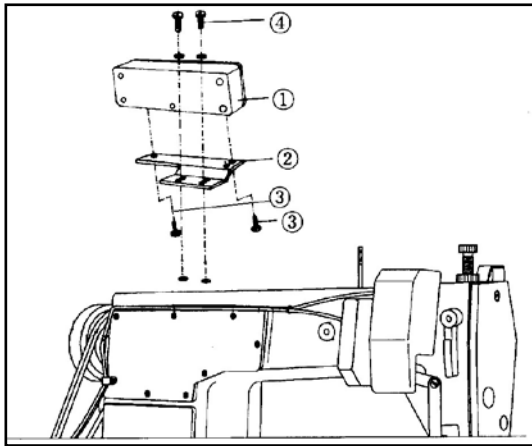

(Fig. 7)

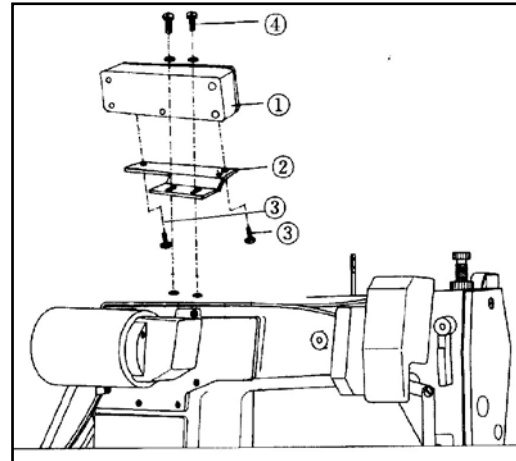

(Fig. 8)

### 3.8) Belt Cover

1. Use the clamp screws (2) in the machine body and the washer (3) to fasten the belt cover "A" (1). Installation of the belt cover will be easier if the sewing machine is laid down to an appropriate degree. (See Fig. 9)

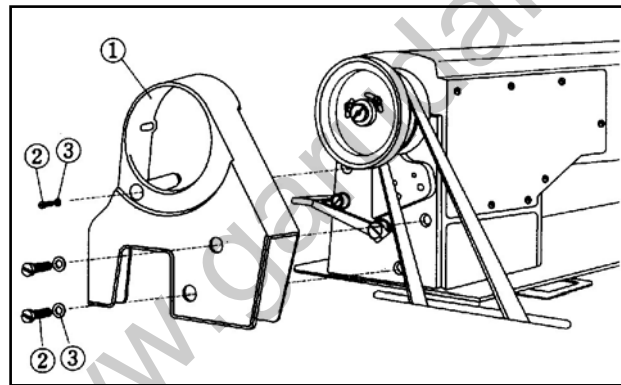

(Fig. 9)

2. Attach the belt cover "B" (4) to the table. Please exercise caution so that the belt does not get jammed inside the belt cover "B" (4). (See Fig. 10)

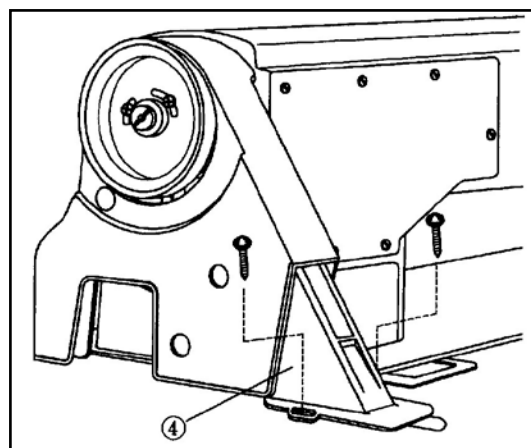

(Fig. 10)

### 3.9) Location Detector Assembly and Adjustment

#### Installing the location detector:

Installing on the servo motor (in-built location detector)

A location detector sensor is attached to the back side of the arm. The appropriate clearance between the location detector and the pulley is 0,5mm. (See Fig. 11)

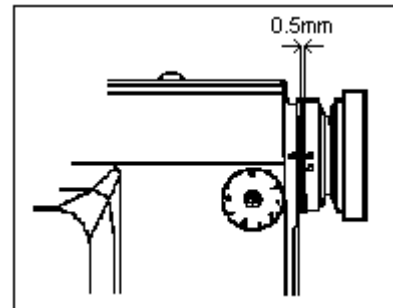

(Fig. 11)

### 3.10) Location Adjustment of Location Detector

#### For in-built location detectors:

Adjust the up-stop position of the needle such that the white carved sign on the pulley (3) is in a straight line with the carved sign on the arm (4) when the needle has stopped in the air. That adjustment can be made by loosening the pulley's clamp screw (1) on the side with N . U carved signs and moving it sideways. Adjust the down-stop position of the needle such that the needle is on the point of moving up when the needle bar is at the lowest point. This adjustment can be made by loosening the pulley's clamp screw (2) on the side with N . D carved signs and moving it sideways. (See Fig. 12 & 13)

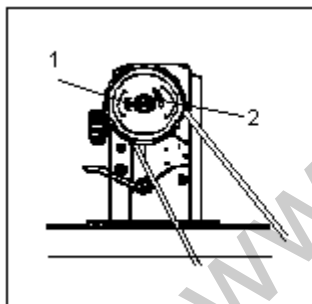

(Fig. 12)

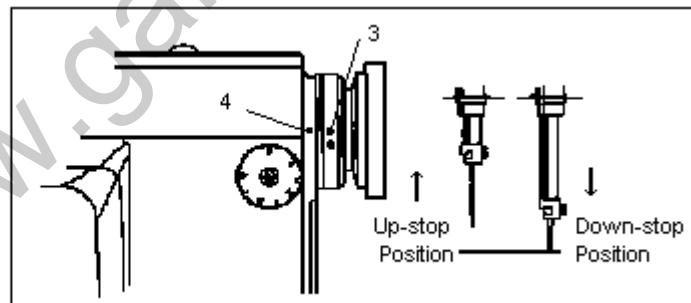

( Fig. 13)

### 3.11) Check for Stop Position of Sewing Machine

Check for the machine stop position after moving the needle up and down by pushing the reverse button. See whether the carved sign on the arm and the white carved sign on the pulley are aligned when the needle is in an up position. If not, adjustment to the photo film of the location detector or to the location of the magnetic holder will be necessary since there may be problems with the trimming. In other words, the needle's up-stop position should be identical with the stop position of the needle bar after the trimming operation, which would signify that there is nothing wrong with the operation timing of the trimmer.

(See Fig. 14)

(Refer to the explanation about the Adjustment of Location Detector on this page no. 11)

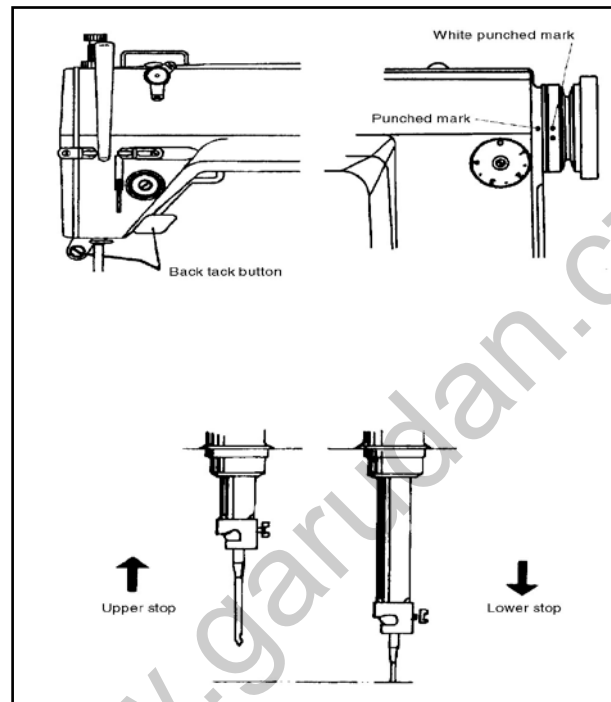

(Fig. 14)

### 3.12) Back Tack Button

Pressing the back tack button of reverse button (1) during forward sewing will start reverse sewing immediately. When you stop the machine and restart it by stepping down on the pedal with the reverse button (1) already pressed down, you can perform reverse sewing from the beginning. When the machine is in a "stop" mode, you can change the up-down position of the needle bar by pressing the reverse button. Lightly pressing the button once when the needle is in a down-stop position will stop the needle bar in a high position. Pressing the reverse button twice within less than a second when it is in an up-stop position will stop the needle bar in a low position. In short, the button delivers two functions: one for reverse sewing and the other for converting vertical position of the needle. (See Fig. 14)

## 4) CONTROL AND ADJUSTMENT OF THE MACHINE



### Caution

Always turn off the power when mounting a needle. If the operator mistakenly steps on the pedal while the power is on, the machine will start automatically and can result in physical injuries. When using clutch motor, be aware that the motor will continue to rotate for a while even after the power is switched off due to inertia. Start to work on the sewing machine only after the motor has come to a complete stop.

#### 4.1) Needle Insertion

With the needle groove (1) facing left, insert the needle tip into the upper end of the stopper hole (2) and fasten the needle with the clamp screw (3). (See Fig.15)

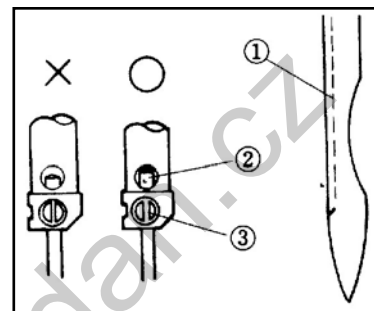

(Fig. 15)

#### 4.2) Needle Bar Adjustment

As is shown in Fig. 16, unscrew the rubber plugs (4) in the needle bar adjustment hole that is on the face plate and turn the pulley so that the needle bar is in a down-stop position. Then turn loose the clamp screws (5) on the needle bar handle, move the needle bar such that the lowest carved sign on the needle bar (7) is in line with the bottom of the needle bar lower bushing (6), and tighten the clamp screws of the needle bar handle. Lastly, plug in the rubber plugs (4).

#### 4.3) Timing Adjustment of Needle and Hook

As can be seen in Fig. 16, align the bottom of the needle bar bushing (6) with the hook fixed position sign (1) marked on the needle bar and loosen the three hook fixing screws (2). Turn the hook so that the edge of the hook (3) is in line with the needle center. Adjust such that the distance between the inside of the groove on the needle side and the edge of the hook (3) is 0,05 - 0,1mm, then tighten the three fixing screws (2) again.

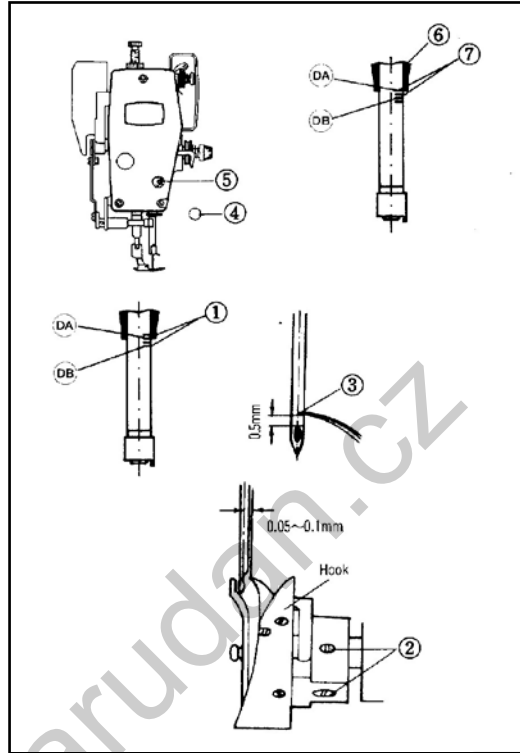

(Fig. 16)

#### 4.4) Lubrication Adjustment of Thread Take-Up Lever

As in Fig. 17, oil flow is at its maximum when the mark (2) on the head of the oil flow control pin (1) and the center of the hole (3) on the thread take-up lever crank shaft is directly aligned. In contrast, oil flow decreases when the mark is turned closer to the corner (5) of the link cam washer (4). Furthermore, if the mark passes the corner of the link cam washer, oil will not flow at all.

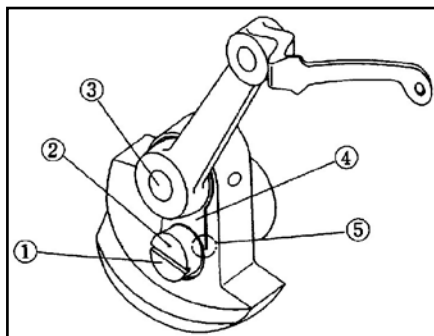

(Fig. 17)



Caution

When checking the oil level in the hook, keep your hands or oil flow checking paper away from any moving parts including transfer tools, to avoid injury.

#### 4.5) Lubrication Adjustment of Hook

##### 1. Checking the oil supply level of hook

A. After racing the sewing machine for three minutes (at an appropriate speed), secure the oil flow checking paper as shown in Fig. 18 and run the machine for about five seconds. Then check the oil tape marked on the paper.

B. Check the oil supply level three times. The appropriate level of oil is when the oil level neither exceeds the maximum amount nor falls below the minimum level. (Insufficient oil would jam the hook, whereas excessive oil would contaminate the sewing material with oil.)

##### 2. Adjustment of the Oil Supply Level

Turn the oil flow adjusting screw (1) in the lower shaft front bushing in a clockwise direction for more oil flow. Turn it counterclockwise for less oil.

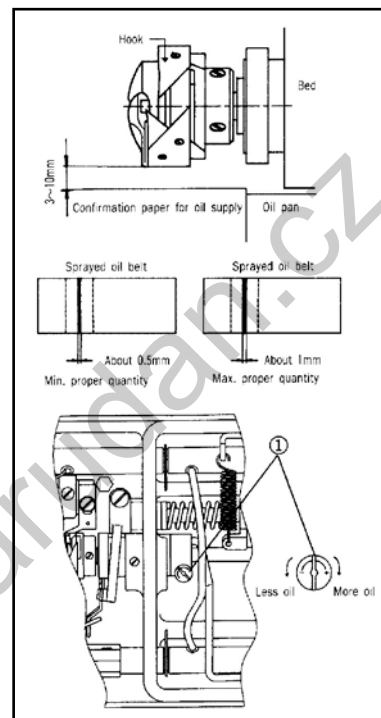

(Fig. 18)



Caution

Turn off the power when adjusting the lower thread tension. If the operator mistakenly steps down on the pedal while switched on, the machine will start automatically and can cause physical injuries.

When using the clutch motor, be aware that the motor will continue to rotate for a while after the power is switched off. Start to work only after the motor has come to a complete stop.



#### 4.6) Inserting Lower Thread and Tension Adjustment

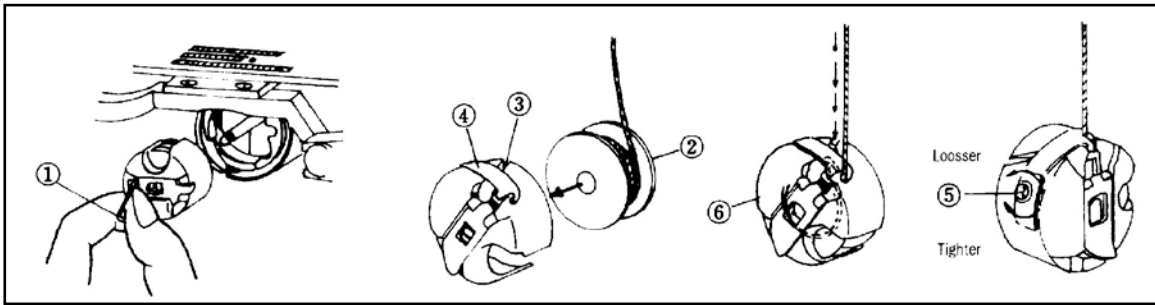

(Fig. 19)

A. After placing a bobbin (2) in a bobbin case (1), push the thread through the thread groove (3) and hook it under the tension adjusting plate spring (4). To tighten the lower thread, turn the tension adjusting screw (5) clockwise; turn it counterclockwise to loosen. Adjust the tension of the lower thread so that it will fall slowly by gravity when the bobbin case (1) is dropped while holding the end of the thread. (See Fig. 19)

#### B. Inserting and Removing the Bobbin Case

Hold the bobbin case handle (6) and insert it into the hook. Pull the handle (6) to remove. (The bobbin (2) will fall out if the handle is let go.) (See Fig. 19)



Caution

Turn off the power switch when routing the upper thread. If the operator mistakenly presses down on the pedal while switched on, the machine will start automatically and can cause physical injuries. When using the clutch motor, be aware that the motor will continue to rotate for a while after the power is switched off. Start to work on the sewing machine only after the motor has come to a complete stop.

#### 4.7) Routing Upper Thread

Place the thread take-up lever at the highest position and route the upper thread in the order indicated in Figures 20 & 21.

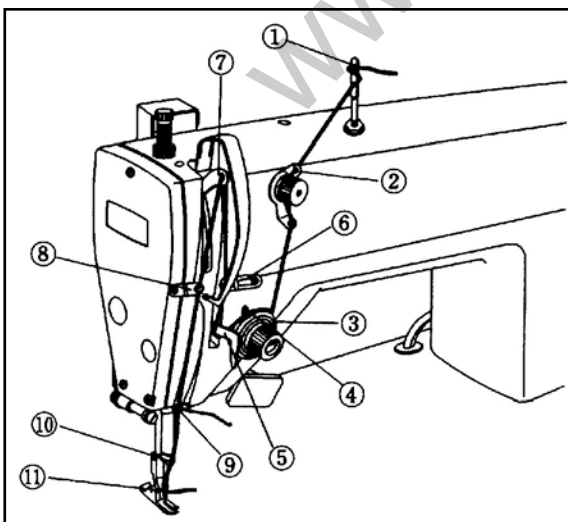

(Fig. 20)

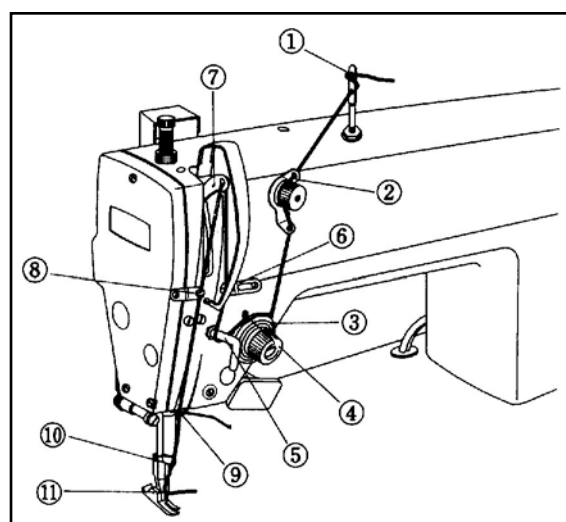

(Fig. 21)

## 4.8) Upper Thread Adjustment

### 1. Main thread adjustment device

The tension of the upper thread gets tighter if the tension adjusting nut (1) as in Fig. 22 is turned in a clockwise direction and it gets looser when turned in the opposite direction. The tension of the thread should differ according to the sewing conditions which depend on the material, thread, stitch length, etc. So the tension should be adjusted as seen fit for the conditions.

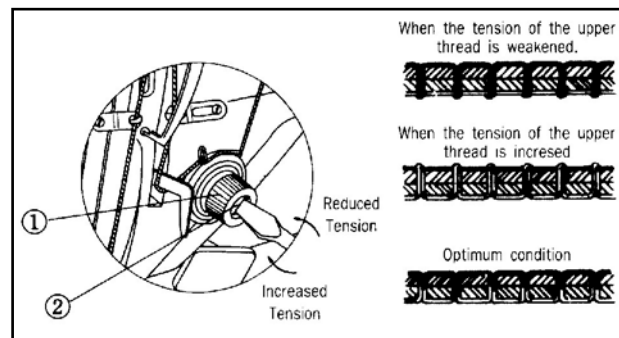

(Fig. 22)

### 2. Tension adjustment of thread take up lever spring

As in Fig. 22, use a driver in the thread adjustment shaft groove (2) to adjust the spring tension. The thread take up lever spring grows tighter when the driver is turned clockwise and looser when turned counter clockwise.

### 3. Auxiliary thread adjuster

Turn the auxiliary thread tension adjusting nut (1) in clockwise direction to make the remaining thread length on the needle after trimming shorter and in counterclockwise direction to make it longer, as shown in Fig. 23. The appropriate length of the upper thread remaining after trimming is 30~40mm.

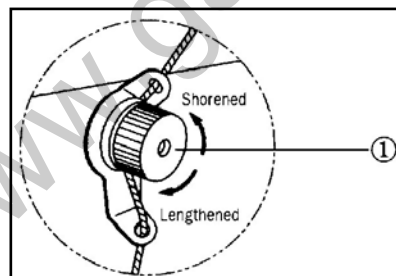

(Fig. 23)

### 4. Thread release control

The thread release takes place simultaneously with the movement of the trimming solenoid. As seen in Fig. 24, the amount of thread release is controlled by moving the fixed position of the thread release wire (2), which is connected with the clutch lever (1), left and right. Loosen the two fixing nuts (3) and pull the cable wire (2) to the left. Then fasten the nuts (3) to release the thread to a large extent. If the cable wire is pushed to the right and the nuts (3) tightened, the thread release happens on a lesser scale.

After adjustment, tighten the nuts (3) once again and check whether the opening of the thread guide plate (4) of the thread adjuster is about 0,5 - 1mm when the thread releaser is in operation. There should be no opening when the thread releaser is not in operation; the thread guide plates (4) should be touching back to back. The moving stroke of the thread release lever (1) is 11mm. Adjust such that the thread guide plate (4) do not open when the cable wire is pulled about 0-8mm and that the plates open when the cable wire is pulled about 8-11mm.

(See Fig. 24)

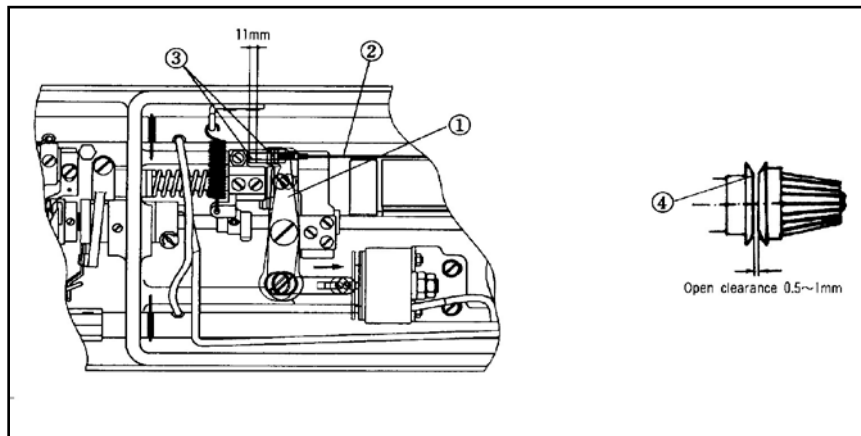

(Fig. 24)

**Caution**

- ▶ After disassembling and adjusting a safety device, always place it back to the original position and check whether it functions as intended.
- ▶ Use both hands when pushing the machine backward or returning it to the original position. Due to the weight of the machine your hand can get stuck in the machine if you should slip.
- ▶ When adjusting the machine with the switch on, be sure to pay extreme caution.
- ▶ Only trained engineers must perform troubleshooting or inspection of the machine.
- ▶ For electrical repair or inspection, consult with qualified technicians or agent.

**4.9) Height and Tension Adjustment of Presser Foot**

1. As in Fig. 25, remove the rubber plug (2) in the face plate and place the presser foot (3) on the needle plate. Then, loosen the presser bar fixing screw (4) and adjust the height of the presser bar. The presser foot (3) will fall when the presser bar is lifted and rise when the presser bar is moved down. Move the presser foot lifter (5) manually to place the bottom face of the presser foot 5,5mm above the top face of the needle plate and tighten the presser bar fixing screws firmly.

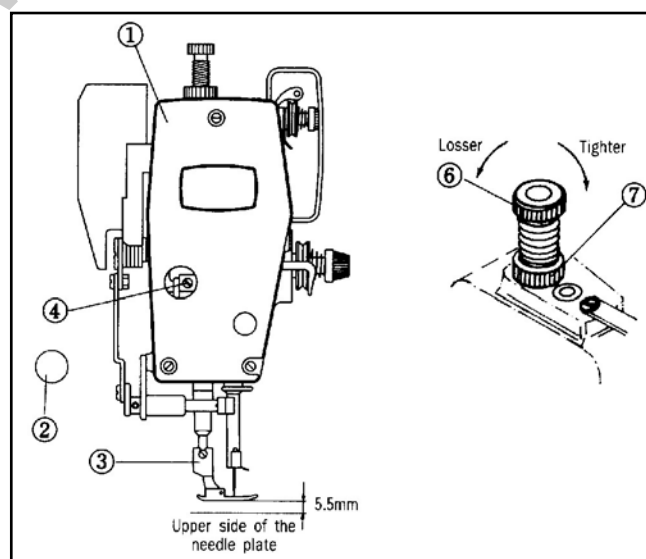

(Fig. 25)

## 2. Tension adjustment

As described in Fig. 25, the tension of the presser foot will grow stronger when the tension adjusting screw (6) is turned clockwise and weaker when turned counterclockwise. Make sure to screw in the fixing nut (1) after adjustment.

### 4.10) Adjustment of Automatic Knee-Lifter (Optional)

An automatic knee-lifter will be attached to the sewing machine at point of delivery. The lifting amount of the presser foot when automatically lifting the knee is controlled by the automatic knee-lifting solenoid shaft crank (1). First, loosen the solenoid cover fixing screw (3) and remove the solenoid cover (2). If the solenoid shaft (5) is moved left and the fixing screw (4) is tightened when the solenoid crank shaft fixing screw (4) is loose, the lifting amount of the presser foot grows smaller. If the solenoid shaft (5) is moved to the right, the lifting amount will grow bigger. Assemble the cover back after the adjustment is completed. (The presser foot lifting amount for the automatic knee-lifter will be set to 13mm by default at point of delivery).

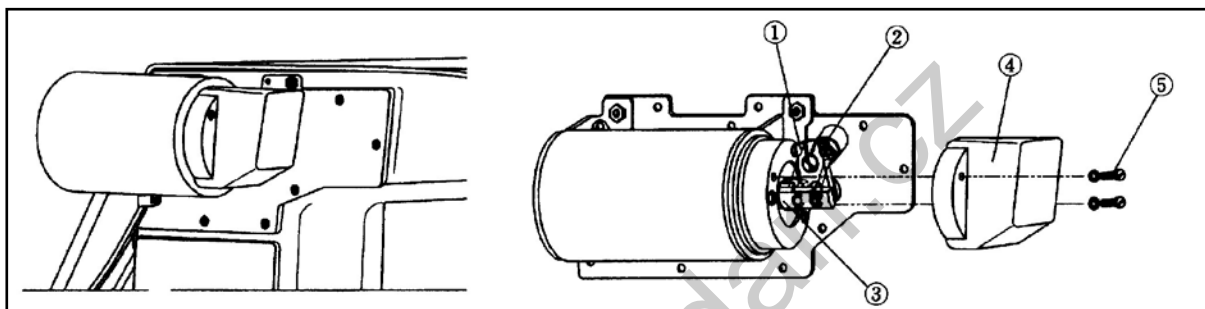

(Fig. 26)

### 4.11) Stitch Length Adjustment

As is shown in Fig. 27, the number marked by the stitch adjusting dial (1) signifies the stitch length in mm units. Move the dial sideways to set it to the desired stitch length (Turn it in clockwise direction and the stitch length will decrease while turning it counterclockwise will increase the stitch length.)

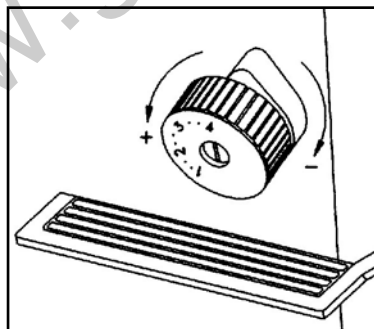

(Fig. 27)

### 4.12) Height and inclination Adjustment of Feed Dog

#### 1. Height adjustment of the feed dog

(\* For GF-1117/GF-1118 series users, the stitch length adjusting dial must be set to "0" here.)

The height of the feed dog is adjusted by moving the lifter crank (1) after the lifter crank fixing screw (2) is loosened. The standard height from the top face of the needle plate to the top of the feed dog when the stitch length dial is at its maximum and the feed dog is at its highest point is:

- 0,60 ~ 0,70mm for very thin materials,
- 0,75 ~ 0,85mm for general materials,
- 1,00 ~ 1,20mm for heavy materials.

(See Fig. 28)

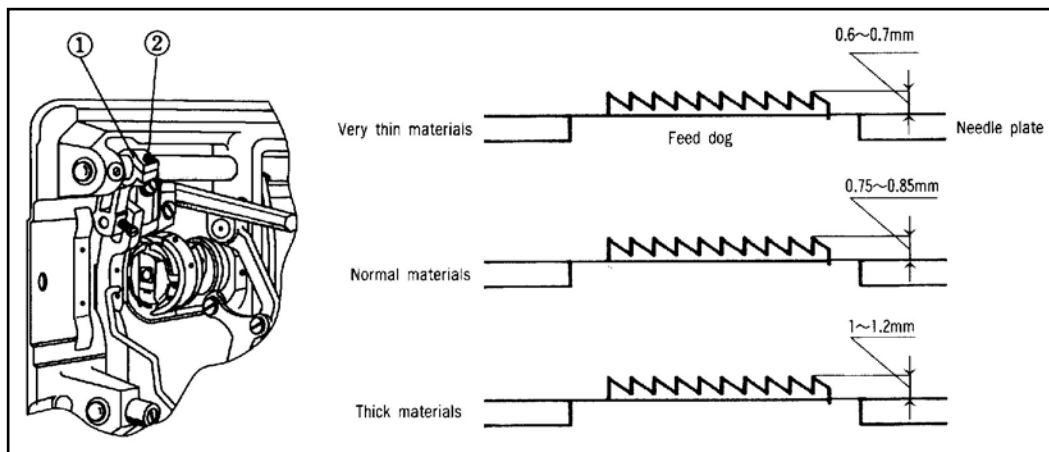

(Fig. 28)

## 2. Inclination adjustment of the feed dog

A. To adjust the inclination of the feed dog, first loosen the feed dog support shaft fixing screw (6) in the horizontal pushing crank (4) and adjust by turning feed dog support shaft (5) up and down in the direction of the arrow with a driver. Turning the feed dog support shaft (5) clockwise will raise the front part of the feed dog, while turning it counterclockwise will lower the front part of the feed dog.

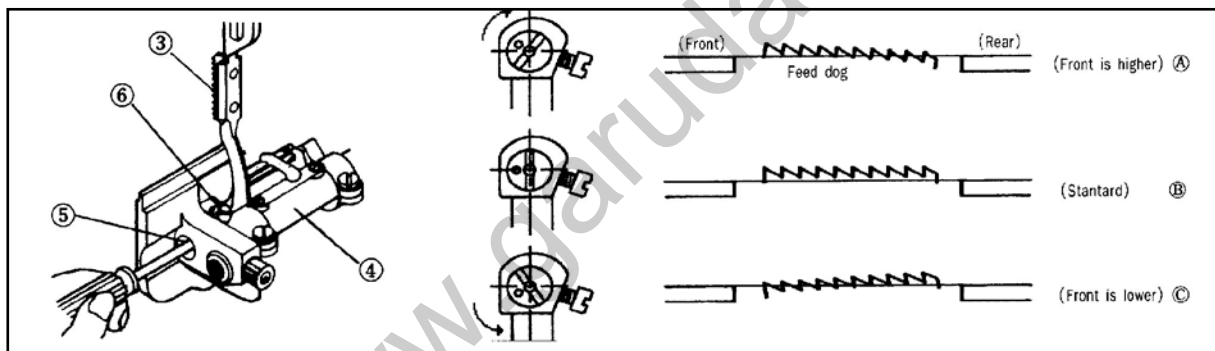

(Fig. 29)

B. The standard inclination of the feed dog is when the carved sign on the feed dog support shaft is horizontally in line with the horizontal pushing crank as in picture (B) in Fig. 29. Also, to prevent material jamming, lower the front of the feed dog as in picture (C) in Fig. 29.

C. Adjustment of the inclination of the feed dog (3) will result in a change in the height of the feed dog, so recheck the height.

### 4.13) Feed Cam Adjustment

The timing of the feed dog and needle is adjusted by turning the feed cam (1) up and down. When the pulley is turned such that the feed dog is lowered so that the top of the feed dog is aligned with the top of the needle plate, the lower needle hole will come in direct line with the top of the feed dog. This is the standard position.

(For the GF-1117/GF-1118 series, the standard is when the end of the needle is in line with the top of the feed dog when the top of the feed dog is aligned in height with the top of the needle plate.)

(\*For GF-1117/GF-1118 series users, the stitch length adjusting dial must be set to "0" here.)

GF-1116

- A. Loosen screws (2) and (3) in feed eccentric cam (1), move the feed eccentric cam in the direction of the arrow or opposite direction of the arrow, and firmly tighten the screws.
- B. For the standard adjustment, adjust so that the top surface of feed dog and the top end of needle eyelet are flush with the top surface of throat plate when the feed dog descends below the throat plate.
- C. To advance the feed timing in order to prevent uneven material feed, move the feed eccentric cam in the direction of the arrow.
- D. To delay the feed timing in order to increase stitch tightness, move the feed eccentric cam in the opposite direction from the arrow. (See Fig.30)

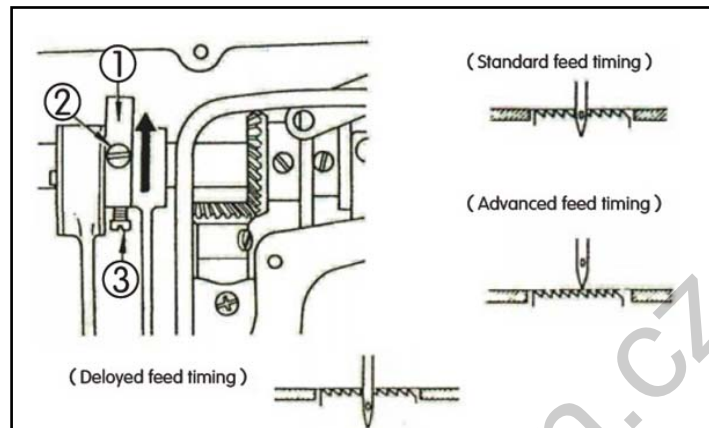
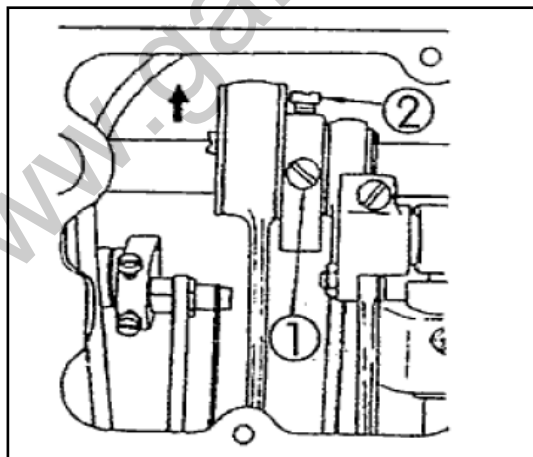

Fig.30

**GF-1117**

- A. Set the feed adjusting dial at 0 on the scale.
- B. For standard feed, loosen setscrew (1) and (2), align the tip of the needle and the top surface of the feed dog with the top surface of the throat plate when the feed dog rises above the throat plate. Then, tighten the setscrew securely. (See Fig.31)



(Fig. 31)

#### 4.14) Adjustment of Needle Movement (GF-1117/GF-1118 series)

1. The standard position is when the needle feed connecting rod (2) is positioned at the carved sign marked on the horizontal pushing crank (back)(1).
2. To increase the feed dog movement over the needle movement, loosen nut (3) and adjust the needle feed connecting rod (4) in (a) direction and then tighten nut (3). The feed dog movement can increase about 20% in excess of the needle movement and this adjustment is especially effective for slippery material or thick material, which are susceptible to jams
3. In contrast, turning the needle feed connecting rod (2) in (b) direction would decrease needle movement such that it would be smaller than the feed dog movement. (See Fig 32)

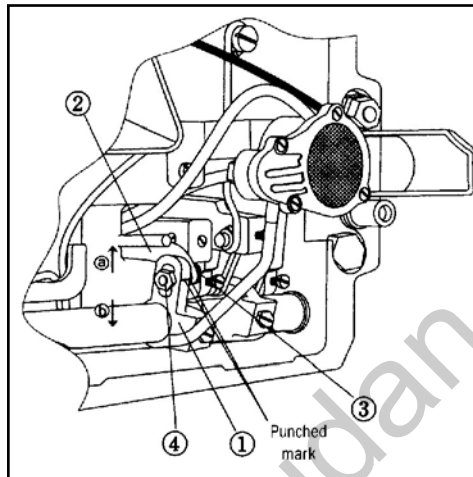

(Fig. 32)

#### 4.15) Timing Adjustment of Trimmer

1. Turn the pulley (1) manually on the pulley and the carved sign (3) on the arm.

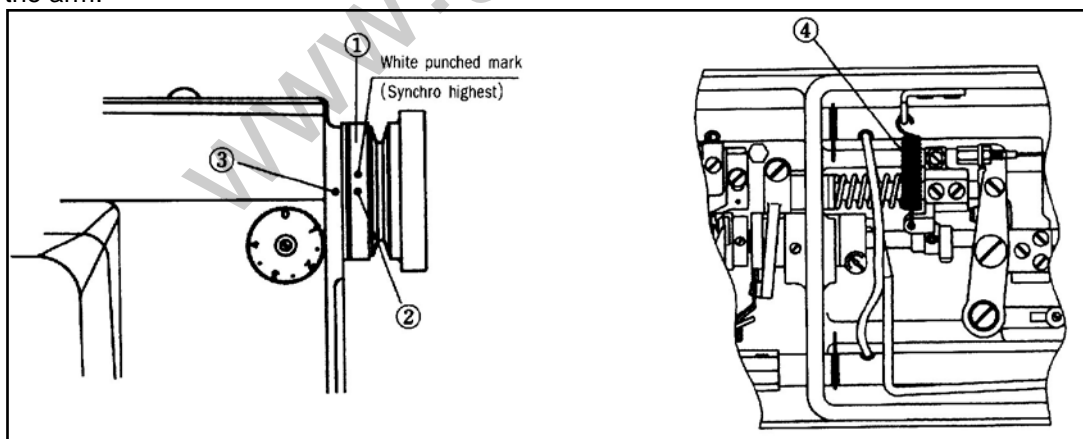

(Fig. 33)

2. Push the trimming lever (5) so that the thread trimming knife (7) on the hill of the movable knife (6) is about 1~1,5mm more protruded than the end point of the fixed blade (8).
3. Push the trimming solenoid shaft (10) manually while the trimming cam fixing screw (9) is loose. (At this point, the appropriate distance between the initial trimming cam (11) and the roller single screw (12) is 0,5mm.)

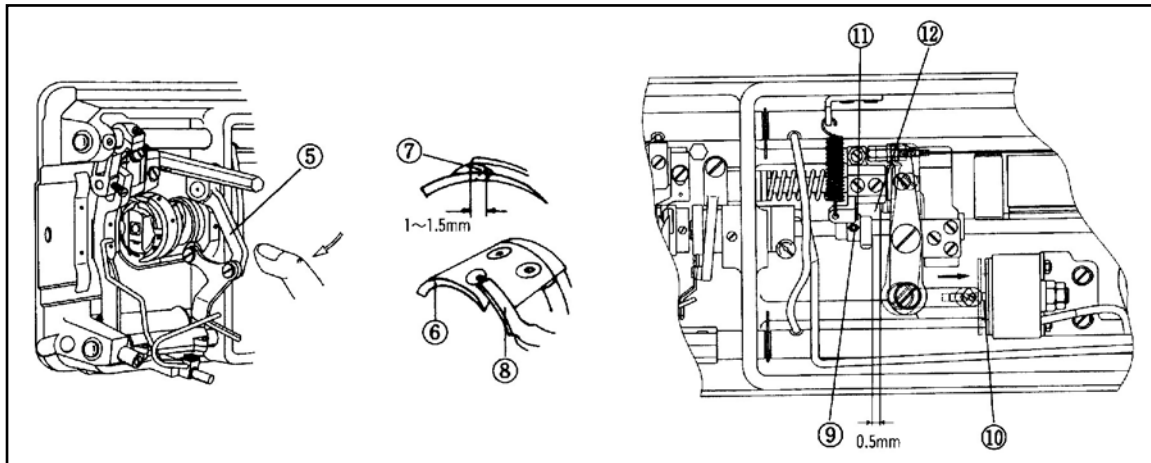

(Fig. 34)

4. Turn the trimming cam (11) manually so that the edge (13) of the roller driving part on the trimming cam (11) touches the roller (14). Then tighten the trimming cam fixing screw (9). (See Fig.35)

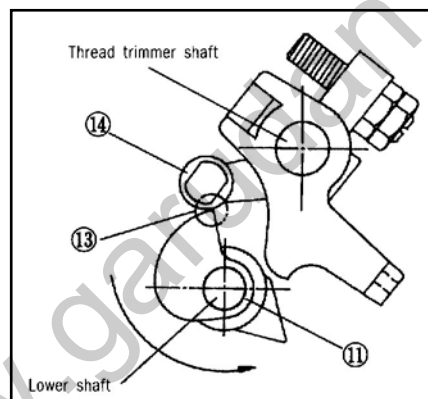

(Fig. 35)

#### 4.16) Tension Adjustment of Fixed Blade

First, loosen the fixed blade tension adjusting nut (1) with a wrench box and then loosen the tension adjusting screw (2). As in Fig.36, adjust the tension adjusting screw of the fixed blade when the movable knife-edge meets the fixed knife-edge. Adjust just enough so that the knife edges meet without too much tension. After adjustment, make sure to tighten the tension adjusting nut (1) using the wrench box in the accessory box.

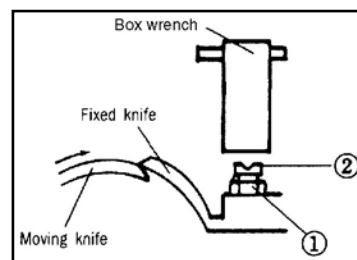

(Fig. 36)



#### 4.17) Replacement of Movable Knife

To change the movable knife (1), turn the pulley manually to place the needle at the highest point. Then, remove the needle plate by unfastening the two movable knife fixing screws (2) as seen in Fig. 37. Follow these instructions in reverse order to assemble.

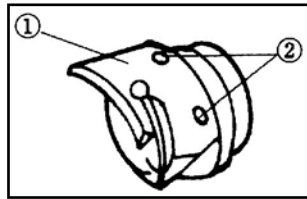

(Fig. 37)

#### 4.18) Replacement of Fixed Blade

A. To change the fixed knife (1), loosen the inner spindle stopper fixing screw (2) as in Fig. 38, remove the washer (3) and inner spindle stopper (4), then unfasten the fixed knife fixing screw (5). Follow these instructions in reverse order to assemble.

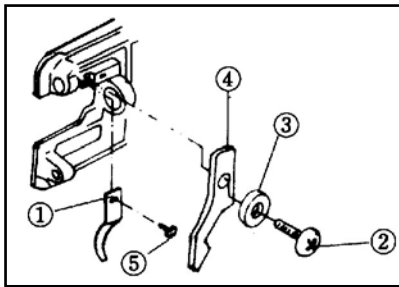

(Fig. 38)

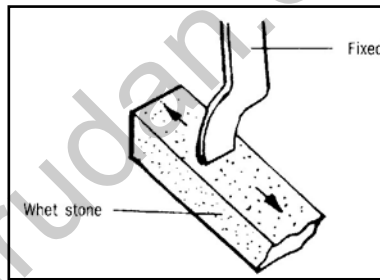

(Fig. 39)

B. If the edge of the fixed blade is worn, make sure to grind the knife edge with an oil grindstone as shown in Fig. 39.

#### 4.19) Adjustment of Bobbin Catcher

If the trimming was done manually, stop the machine when the edge of the fixed knife meets the bobbin catcher adjustment baseline that is marked on the top. Loosen the bobbin catcher fixing screw (5) and adjust the bobbin catcher so that the contact surface of the bobbin catcher (4) lightly touches the center of the protruding part of the bobbin (1). Once the operation is completed, check to see whether the bobbin catcher springs back lightly. (See Fig. 40)

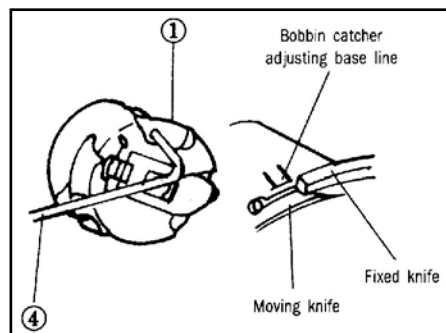

(Fig. 40)

## 4.20) Wiper Adjustment

### 1. GF-1117-447 H

Turn the pulley manually and stop when the white carved signs on the arm and the pulley are aligned. (Highest point of the thread take up lever.) Loosen the two wiper shaft fixing screws (1) on the wiper base and press the connecting link (2) with the hand. Then adjust the wiper shaft (3) so that the gap between the wiper and the needle is about 2mm and tighten the wiper shaft fixing screw (1). Next, loosen the wiper fixing screw (4) and adjust so that the gap between the lower end of the wiper and the end of the needle is about 2mm, after which the wiper fixing screw (4) must be tightly fastened. (See Fig. 41 & 42)

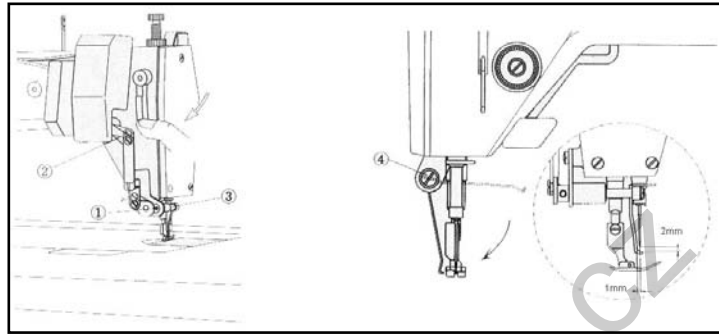

(Fig 41 & 42)

### 2. GF-1116-147LM / GF-1118-147LM series

Set the stitch length adjusting dial to "2".

Turn the pulley manually and stop when the white carved signs on the arm and pulley are in a straight line. (Highest point of the thread take up lever). At this point, position the wiper so that the needle and the presser foot are about 2mm apart and then fix the position. (See Fig.43)

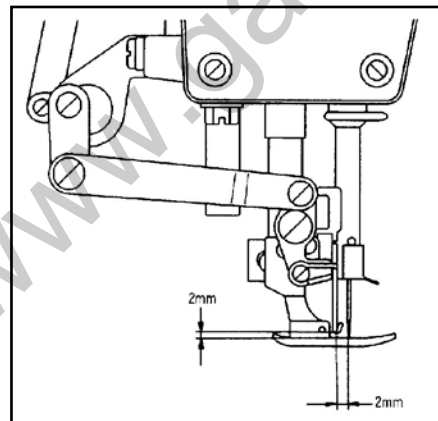

(Fig. 43)

#### 4.21) Knife Adjustment (GF-1116-147 LM / GF-1118-147 LM)

##### 1. Adjusting the height of the knife

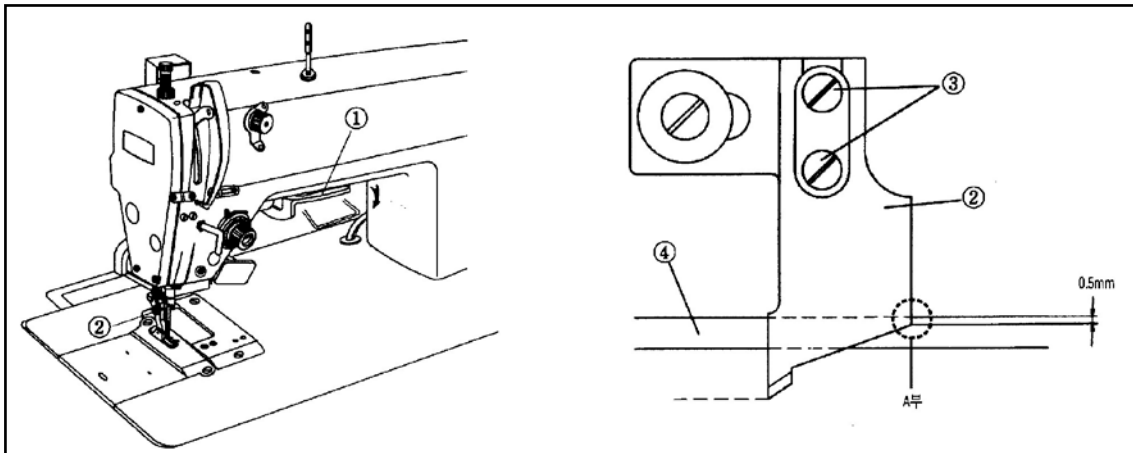

(Fig. 44)

- A. The knife (2) is operated by the lever (1) at the center of the sewing machine. If the lever (1) is pulled down, the cutting and sewing of the material can be done simultaneously. If the lever (1) is pulled up, sewing is done without cutting.
- B. Loosen the knife fixing screw (3) when the lever (1) is pulled down and adjust so that Area A of knife (2) is about 0,5mm above the top face of the needle plate (4). Then, tighten the knife fixing screw (3). (See Fig.44)

##### 2. Adjusting the front-back position of the knife

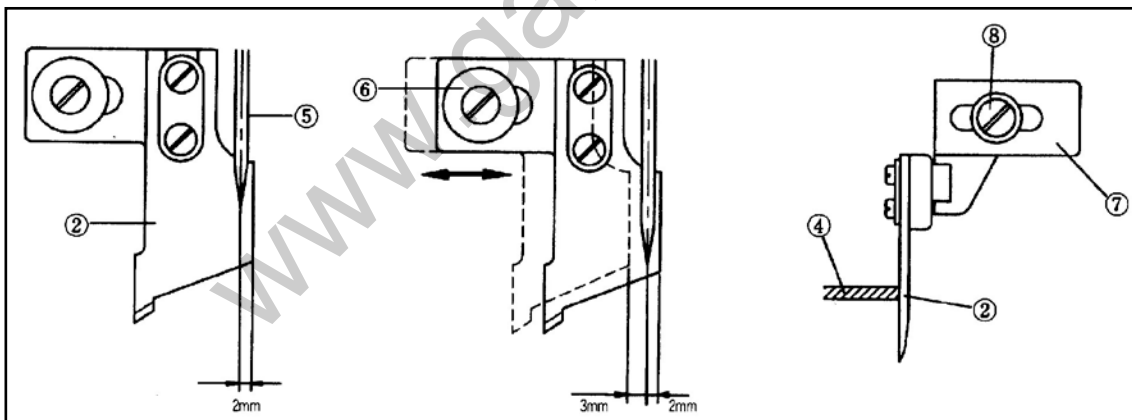

(Fig. 45)

- A. Set the stitch length adjusting dial to "0".
- B. The standard position of the knife is when the edge of the knife (2) is about 2mm in front of the needle (5) center.
- \* For GF-1116 series, the end of the knife (2) and the center of the needle (5) should match.
- To adjust the front-back position of the knife, loosen the knife plate fixing screw (6) and move the knife plate back and forth. The adjustable width range of the knife edge is from 2mm forward to 3mm backward from the needle center.

##### 3. Adjusting the left-right position of the knife

- A. To adjust the left-right position of the knife (2), loosen the knife frame fixing screw (7) and move the knife frame (7) sideways.

- B. After loosening the knife frame fixing screw (7) and adjusting the knife side so that it would touch the side of the needle plate (4), tighten the fixing screw (7),
- C. If the knife (3) is too close to the needle plate (4), there may be an overload on the knife when in operation; on the other hand, if the adhesion is too weak, there may be problems when cutting the material. Therefore, the lever (1) must always be operated after adjustment to check whether the knife (2) movement is smooth.

#### 4.22) Use of Chip Discharge Guide and Auxiliary Needle Plate (GF-1116/GF-1118 series)

##### 1. When Cutting and Sewing Simultaneously

When cutting and sewing are done at the same time, attach the chip discharge guide (2), which is provided in the accessory box, to the auxiliary needle plate (1) with fixing screws (3). (See Fig.46)

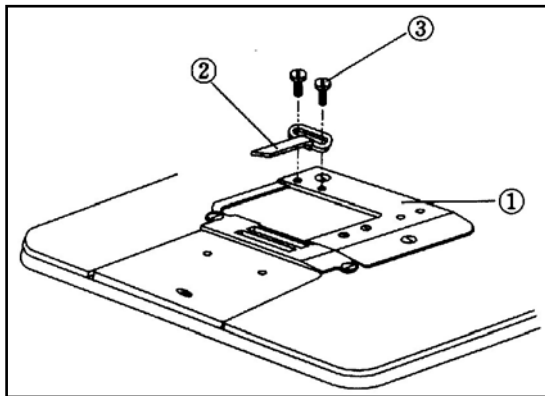

(Fig. 46)

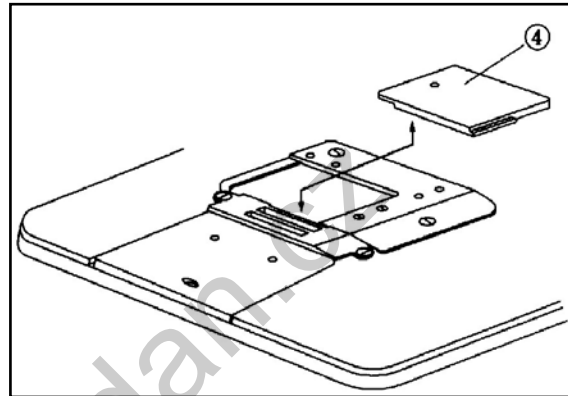

(Fig. 47)

##### 2. When Sewing Only

When sewing is done alone without cutting, remove the chip discharge guide (upper) (2) and the insert the auxiliary needle plate cover (4), which is provided in the accessory box, into the chip discharge groove in the auxiliary needle plate. (See Fig. 47)

#### 4.23) Change of Cutting Width

##### 1. Disassembly

- A. Loosen the needle fixing screw (1) and remove the needle (2).
- B. Loosen the presser foot fixing screw (3) and separate the presser foot (4).
- C. Loosen the needle plate fixing screw (5) and separate the needle plate (6).
- D. Loosen the feed dog fixing screw (7) and separate the feed dog (8).
- E. Loosen the auxiliary needle plate fixing screw (9) and separate the auxiliary needle plate (10).
- F. Loosen the chip discharge guide (lower) fixing screw (11) from the separated auxiliary needle plate (9) and separate the chip discharge guide (12).
- G. Loosen the knife fixing screw (13) and separate the knife (14). (See Fig.48)

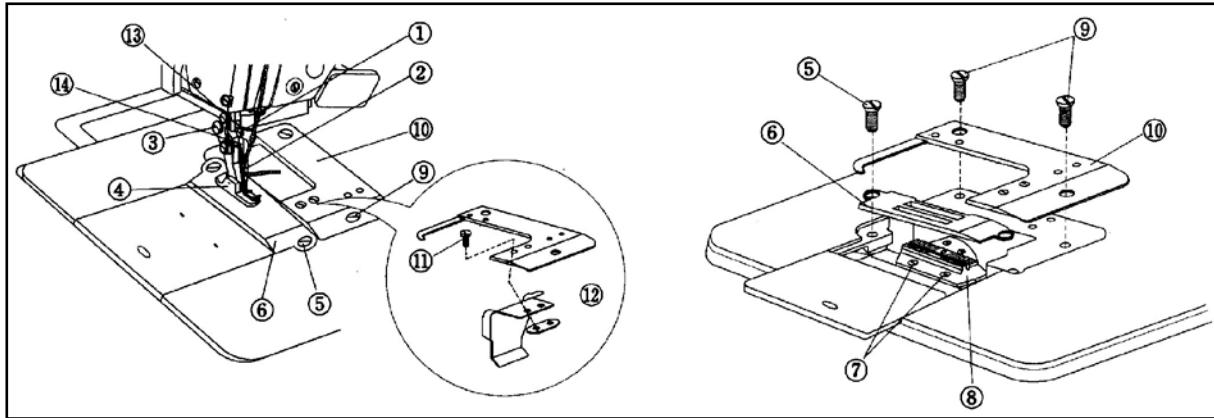

(Fig. 48)

## 2. Assembly

- A. Replace the chip discharge guide (lower) (12) with the one fit for the desired cutting width and fix it with the auxiliary screw (11) on the auxiliary needle plate (10).
- B. Fix the auxiliary needle plate (10) using two fixing screws (9) on the bed.
- C. Fix the feed dog (8) using the fixing screw (7).
- D. Fix the needle plate (6) on the bed using two fixing screws (5).

\* Turn the pulley manually to check whether the space between the feed dog and needle plate during feed dog movement is equal in all directions. Then, adjust the knife frame to adjust the knife position.

\* Move the chip discharge guide (lower) (12) to the left and right so that it is placed 0,05mm from the knife plate side (6). Then, use the fixing screw (11) to fix the position.

- E. Adjust the knife frame so that the pressure of the knife (14) and the needle plate side (6) is appropriate. Then, tighten the fixing screw. (Refer to the explanation about knife position adjustment.)
- F. Attach the presser foot (4) and tighten the fixing screw (3).
- G. Fix the needle (2) with the fixing screw (1).
- H. Adjust the knife position adjusting plate (7) to get the desired cutting width and tighten the fixing screw (8) after adjustment.

\* After assembly, refer to the knife position adjustment instructions on page 22 and readjust.

## 5) Cause of troubles and troubleshooting

### 1) Sewing machine troubleshooting

No	Symptom	Checkpoints	Root cause	Corrective action
1	Needle breaks	Direction and height of needle	Needle is inserted into wrong position.	Reinsert the needle correctly.
		Needle	Needle is bent.	Change the needle.
			Bad timing of feed dog.	Adjust the timing of feed dog.
		Ascending level of needle bar	Bad timing of needle and hook.	Adjust the timing of needle and hook.
		Height of needle	Bad timing of needle and hook.	Adjust the timing of needle and hook.
		Gap between needle and hook	Bad timing of needle and hook.	Adjust the timing of needle and hook.
2	Thread breaks	Threading method	Wrong threading.	Thread the needle correctly.
		Needle	Bent needle or broken needle tip.	Change the needle.
		Direction and height of needle	Needle inserted in the wrong position.	Insert the needle correctly.
		Upper thread tension	Too tight upper thread tension.	Reduce tension of upper thread.
		Lower thread tension	Too loose lower thread tension.	Reduce tension of lower thread.
		Working capacity of take-up lever spring	Loose upper thread.	Adjust take-up lever spring.
3	Stitch skips	Direction and height of needle	Needle inserted in the wrong position.	Reinsert the needle in the right direction.
		Needle	Bent needle or broken needle tip.	Change the needle.
		Threading	Thread passing at wrong position.	Change the needle.
		Ascending level of needle bar	Wrong timing of needle and hook.	Adjust the timing of needle and hook.
		Height of needle bar	Wrong timing of needle and hook.	Adjust the timing of needle and hook.
		Gap between needle and hook	Wrong timing of needle and hook.	Adjust the timing of needle and hook.
			Remaining length of upper thread is short.	Adjust the thread adjusting device.
		Racing-proof spring of bobbin case	Due to bobbin racing during trimming, lower thread dropping from bobbin case becomes too short to go up.	Change the racing protection spring.
		Take-up lever spring	Unable to lift lower thread due to weak take-up lever spring.	Adjust the working capacity of take-up lever spring.
4	Upper thread does not sink.		Too tight upper thread tension.	Reduce tension of upper thread.
			Too loose lower thread tension.	Increase tension OF lower thread.
5	Lower thread does not sink.		Too tight upper thread tension.	Too strong lower thread tension.
			Increase tension of upper thread.	Decrease tension of lower thread.
	Trimming errors	Tension of fixed blade	Tension not aligned between movable and fixed blade.	Adjust tension of movable and fixed blade.
		Edge of movable and fixed blades	Abrasion in blade groove of movable and fixed blade.	Replace movable and fixed blade.
		Direction of needle	Wrong needle insertion.	Reinsert the needle correctly.
		Check the crossing of trimmer cam notch mark and blade	Insufficeient crossing quantity of movable and fixed blade.	Adjust the stroke of movable and fixed blade.
7	Upper thread is pulled out when sewing commences.		Too strong upper thread tension.	Adjust tension of upper thread.
			Too thick a needle for thread.	Check thickness of needle.
		Check th up-stop position of needle	Take-up lever pulls out the upper thread because the needle up and down position is too high.	Adjust the up-stop position of needle.

Katalog náhradních dílů  
Spare Parts List

**GARUDAN**®

**GF-1117-447 H**



ANITA B s.r.o.

Průmyslová 2453/7

680 01 Boskovice

Czech Republic

tel: +420 516 454 774

+420 516 453 496

fax: +420 516 452 751

e-mail: [info@anita.cz](mailto:info@anita.cz)

[www.garudan.cz](http://www.garudan.cz)

Všechna práva vyhrazena.

Vlastnictví Anita B s r.o. a chráněno autorským právem. Použití tohoto obsahu bez písemného souhlasu Anita B s r.o. zakázáno.

Copyright © Anita B s r.o. (2016)

All rights reserved

All rights reserved property of Anita B and protected by copyright. The use of this content without written permission is prohibited. Copyright © Anita B s r.o. (2016)



**Content/Obsah:**

1. ARM BED AND ITS ACCESSORIES (1/2).....	4
1. ARM BED AND ITS ACCESSORIES (2/2).....	6
2. MAIN SHAFT THREAD TAKE-UP LEVER MECHANISM .....	8
3. NEEDLE BAR UPRIGHT SHAFT LOWER SHAFT MECHANISM.....	10
4. PRESSER FOOT MECHANISM (1/2) .....	12
4. PRESSER FOOT MECHANISM (2/2) .....	14
5. FEED MECHANISM.....	16
6. FEED CONTROL MECHANISM .....	18
7. THREAD TRIMMER MECHANISM (1/2) .....	20
7. THREAD TRIMMER MECHANISM (2/2) .....	22
8. NEEDLE FEED MECHANISM .....	24
9. AUTOMATIC REVERSE FEED MECHANISM .....	26
10. WIPER COMPONENTS MECHANISM.....	28
11. OIL LUBRICATION MECHANISM.....	30
12. ACCESSORIES (1/3) .....	32
12. ACCESSORIES (2/3) .....	34
12. ACCESSORIES (3/3) .....	36

1. ARM BED AND ITS ACCESSORIES (1/2)

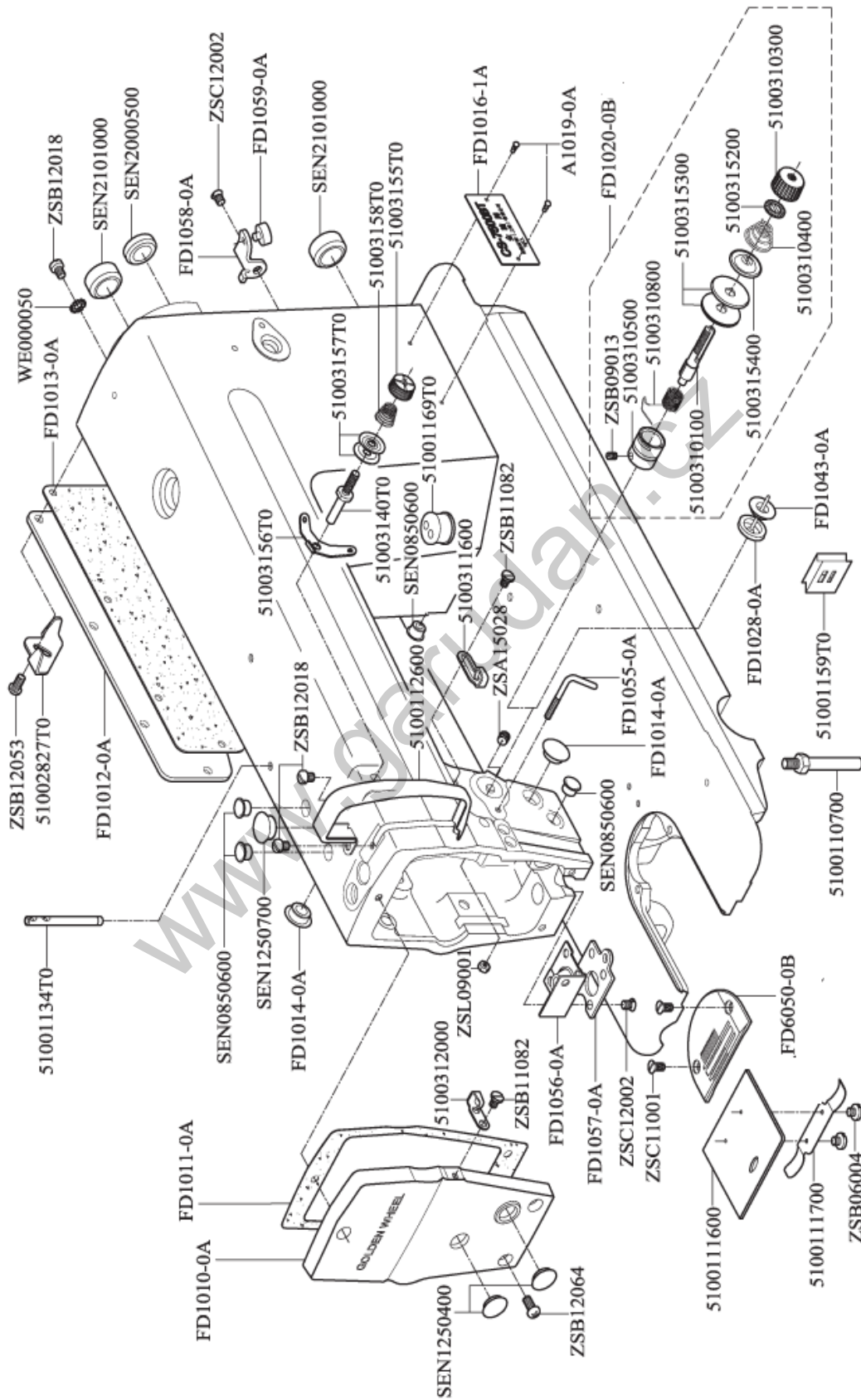

<b>1. ARM BED AND ITS ACCESSORIES (1/2)</b>			
<b>PARTS. NO</b>	<b>NAME OF PARTS</b>	<b>QTY</b>	<b>NOTE</b>
5100110700	Bed Screw Stud	4	
5100111600	Slide Plate	1	
5100111700	Slide Plate Spring	1	
5100112600	Thread Take-up Lever Cover	1	
5100310100	Tension Post	1	
5100310300	Tension Nut	1	
5100310400	Tension Spring	1	
5100310500	Tension Post Socket	1	
5100310800	Take-up Spring	1	
5100311600	Arm Thread Guide	1	
5100312000	Arm Thread Guide	1	
5100315200	Rotating Stopper	1	
5100315300	Thread Tension Disk	2	
5100315400	Thread Tension Disk Presser	1	
51001134T0	Thread Guide Rod	1	
51001159T0	Rubber Plate	1	
51001169T0	Magnet Cord Rubber	1	
51002827T0	Tension Plate	1	
51003140T0	Tension Post	1	
51003155T0	Tension Nut	1	
51003156T0	Thread Tension Guide	1	
51003157T0	Tension Plate	2	
51003158T0	Tension Spring	1	
A1019-0A	Pin	2	
FD1010-0A	Face Plate Asm	1	
FD1011-0A	Face Plate Gasket	1	
FD1012-0A	Side Plate	1	
FD1013-0A	Gasket	1	
FD1014-0A	Rubber Plug	2	
FD1016-1A	Name Plate	1	
FD1028-0A	Tension Release Pin Cap Asm	1	
FD1043-0A	Cap Ring	1	
FD1055-0A	Arm thread Guide	1	
FD1056-0A	Gasket	1	
FD1057-0A	Presser Bar Support	1	
FD1058-0A	Lever Stopper Asm	1	
FD1059-0A	Underlay	1	
FD6050-0B	Throat Plate	1	

1. ARM BED AND ITS ACCESSORIES (2/2)

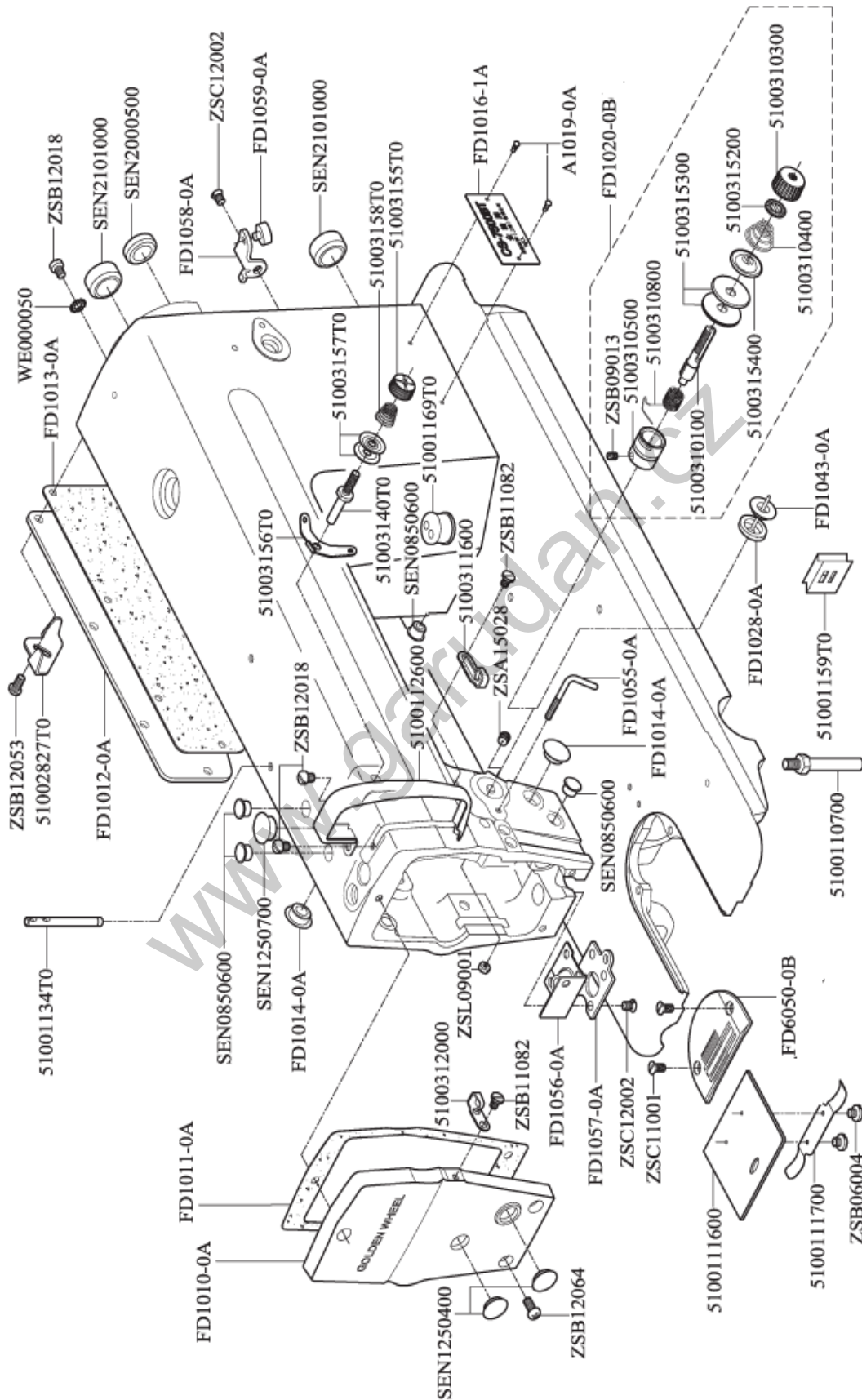

<b>1. ARM BED AND ITS ACCESSORIES (2/2)</b>			
<b>PARTS. NO</b>	<b>NAME OF PARTS</b>	<b>QTY</b>	<b>NOTE</b>
SEN0850600	Rubber Plug	4	
SEN1250400	Rubber Plug	2	
SEN1250700	Rubber Plug	1	
SEN2000500	Rubber Plug	1	
SEN2101000	Rubber Plug	2	
WE000050	Washer	1	
ZSA15028	Screw (15/64-28x7)	1	
ZSB06004	Screw (3/32-56x2.2)	2	
ZSB09013	Screw (9/64-40x4)	1	
ZSB11082	Screw (11/64-40x6.5)	2	
ZSB12018	Screw (3/16-28x6)	3	
ZSB12053	Screw (3/16-28x9)	8	
ZSB12064	Screw (3/16-28x10)	3	
ZSC11001	Screw (11/64-40x6.5)	2	
ZSC12002	Screw (3/16-28x3.5)	5	
ZSL09001	Nut (9/64-40)	1	

## 2. MAIN SHAFT THREAD TAKE-UP LEVER MECHANISM

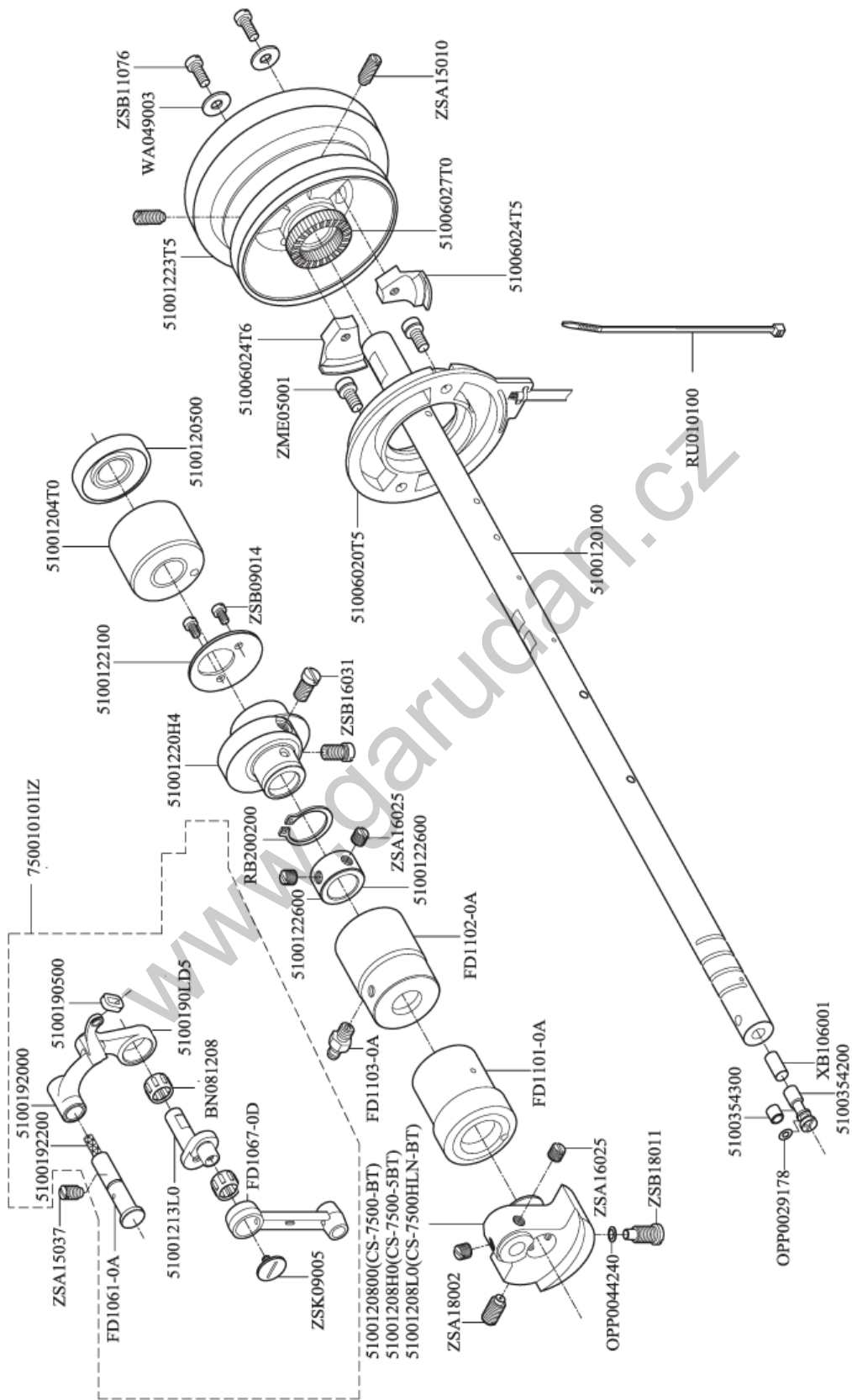

<b>2. MAIN SHAFT THREAD TAKE-UP LEVER MECHANISM</b>			
<b>PARTS. NO</b>	<b>NAME OF PARTS</b>	<b>QTY</b>	<b>NOTE</b>
5100120100	Main Shaft	1	
5100120500	Oil Seal	1	
51001208L0	Counter Weight	1	
51001220H4	Feed Drive Eccentric Cam	1	
51001213L0	Needle Bar Crank	1	
5100122100	Thrust Collar	1	
5100122600	Thrust Collar Asm	1	
5100190LD5	Wiper lever	1	
5100190500	Rubber	1	
5100192000	Lever	1	
5100192200	Oil Thread	1	
5100354200	Oil Amount Adjusting Pin	1	
5100354300	Oil Adjusting Collar	1	
51001204T0	Main Shaft Bushing, Rear	1	
51001223T5	Flywheel Asm	1	
51006024T5	Magnet Fitting Base A Asm	1	
51006024T6	Magnet Fitting Base B Asm	1	
51006027T0	Magnet C	1	
BN081208	Roller Bearing	2	
FD1061-0A	Thread Take-up Crank Shaft Asm	1	
FD1067-0D	Needle Bar Crank Rod	1	
FD1101-0A	Front Bushing	1	
FD1102-0A	Intermediate Bushing	1	
FD1103-0A	Joint	1	
OPP0029178	Rubber Ring	1	
OPP0044240	Rubber Ring	1	
RB200200	Snap Ring	1	
RU010100	Clip	1	
WA049003	Washer	2	
XB106001	Roller Felt	1	
ZME05001	Screw (M5-0.8x9.3)	2	
ZSA15010	Screw (15/64-28x13)	2	
ZSA15037	Screw (15/64-28x8.5)	1	
ZSA16025	Screw (1/4-40x6)	4	
ZSA18002	Screw (9/32-28x11.5)	1	
ZSB09014	Screw (9/64-40x6)	2	
ZSB11076	Screw (11/64-40x12)	2	
ZSB16031	Screw (1/4-40x11)	2	
ZSB18011	Screw (9/32-28x11)	1	
ZSK09005	Screw (9/64-40x6)	1	

### 3. NEEDLE BAR UPRIGHT SHAFT LOWER SHAFT MECHANISM

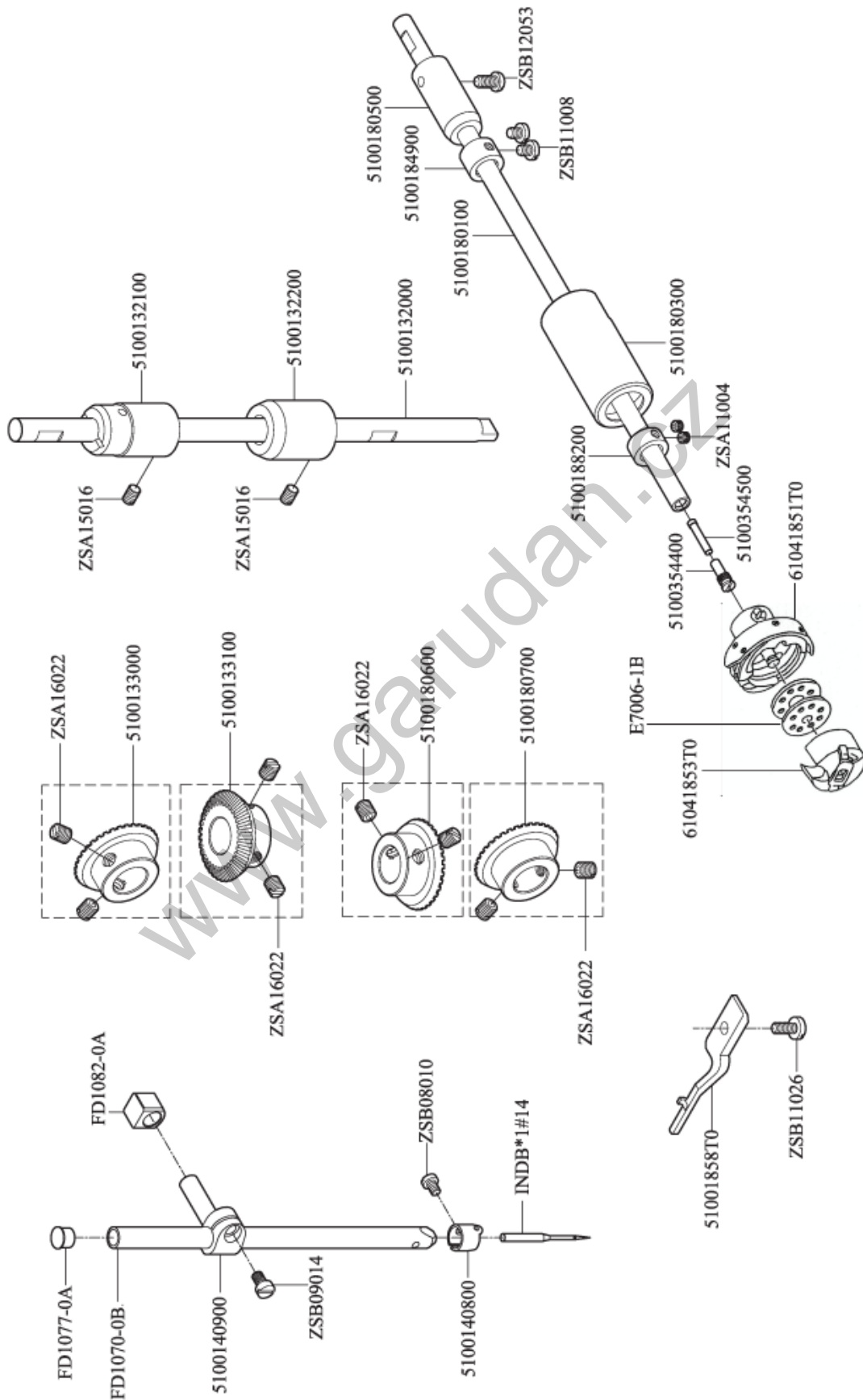



### 3. NEEDLE BAR UPRIGHT SHAFT LOWER SHAFT MECHANISM

PARTS. NO	NAME OF PARTS	QTY	NOTE
5100132000	Upright Shaft	1	
5100132100	Upright Shaft Bushing Upper	1	
5100132200	Upright Shaft Bushing Lower	1	
5100133000	Gear Asm	1	
5100133100	Pinion Asm	1	
5100140800	Needle Thread Guide	1	
5100140900	Needle Bar Connecting Asm	1	
5100180100	Hook Driving Shaft	1	
5100180300	Hook Driving Shaft Bush	1	
5100180500	Bushing, Rear	1	
5100180600	Gear Asm	1	
5100180700	Pinion Asm	1	
E-7006-1B	Bobbin	1	
5100184900	Thrust Collar Asm	1	
5100188200	Thrust Collar Asm	1	
5100354400	Oil Seal Screw	1	
5100354500	Oil Wick	1	
61041853T0	Bobbin Case Asm	1	
61041851T0	Hook Asm	1	
51001858T0	Bobbin Case Positioning Finger	1	
FD1070-0B	Needle Bar	1	
FD1077-0A	Rubber Plug	1	
FD1082-0A	Slide Block	1	
INDB*1#14	Needle	1	
ZSA11004	Screw (11/64-40x3.5)	2	
ZSA15016	Screw (15/64-28x7)	2	
ZSA16022	Screw (1/4-40x7)	8	
ZSB08010	Screw (1/8-44x4.6)	1	
ZSB09014	Screw (9/64-40x6)	1	
ZSB11008	Screw (11/64-40x5)	2	
ZSB11026	Screw (11/64-40x10)	1	
ZSB12053	Screw (3/16-28x9)	1	



<b>4. PRESSER FOOT MECHANISM (1/2)</b>			
<b>PARTS. NO</b>	<b>NAME OF PARTS</b>	<b>QTY</b>	<b>NOTE</b>
5100141200	Holder	1	
5100150100	Presser Bar	1	
5100150300	Presser Spring Regulator	1	
5100150400	Presser Spring	1	
5100150700	Hand Lifter Cam Asm	1	
5100150800	Hand Lifter	1	
5100151500	Nut	1	
5100154800	Presser Guide Bar	1	
5100340400	Lifting Lever Connecting Rod	1	
5100344000	Hand Lifter Link	1	
5100344005	Hand Lifter Link	1	
7162270111	Spring	1	
51003160T0	Wire Holder	2	
51003161T0	Wire Holder Bracket	1	
510034400A	Connecting Pin	2	
EP1179-0A	Belt	1	
EP1182-0B	Belt	1	
FD1181-0B	Presser Bar Bushing Lower	1	
FD1185-0A	Needle Bar Guide Bracket Asm	1	
FD1186-0A	Pin	1	
FD1187-0A	Lifting Lever	1	
FD1189-0A	Tension Release Plate	1	
FD1190-0A	Connecting Pin	1	
FD1191-0A	Connecting Plate	1	
FD1192-0A	Lifting Lever Link	1	
FD1193-0A	Connecting Rod	1	
FD1194-0A	Tension Release Plate Asm	1	
FD1195-0A	Wire Presser Plate	1	
FD1196-0A	Wire Cable Holder	1	
FD1209-0A	Thrust Collar Asm	1	
FD1210-0A	Spring	1	
FD1211-0A	Tension Release Ring	1	
75001532T5	Presser Foot Asm	1	
FD1237-1A	Presser Foot Asm	1	
OPP0037178	Rubber Ring	1	
RE000030	E-Ring	3	
RE000050	E-Ring	2	
WA060034	Washer	1	

4. PRESSER FOOT MECHANISM (2/2)

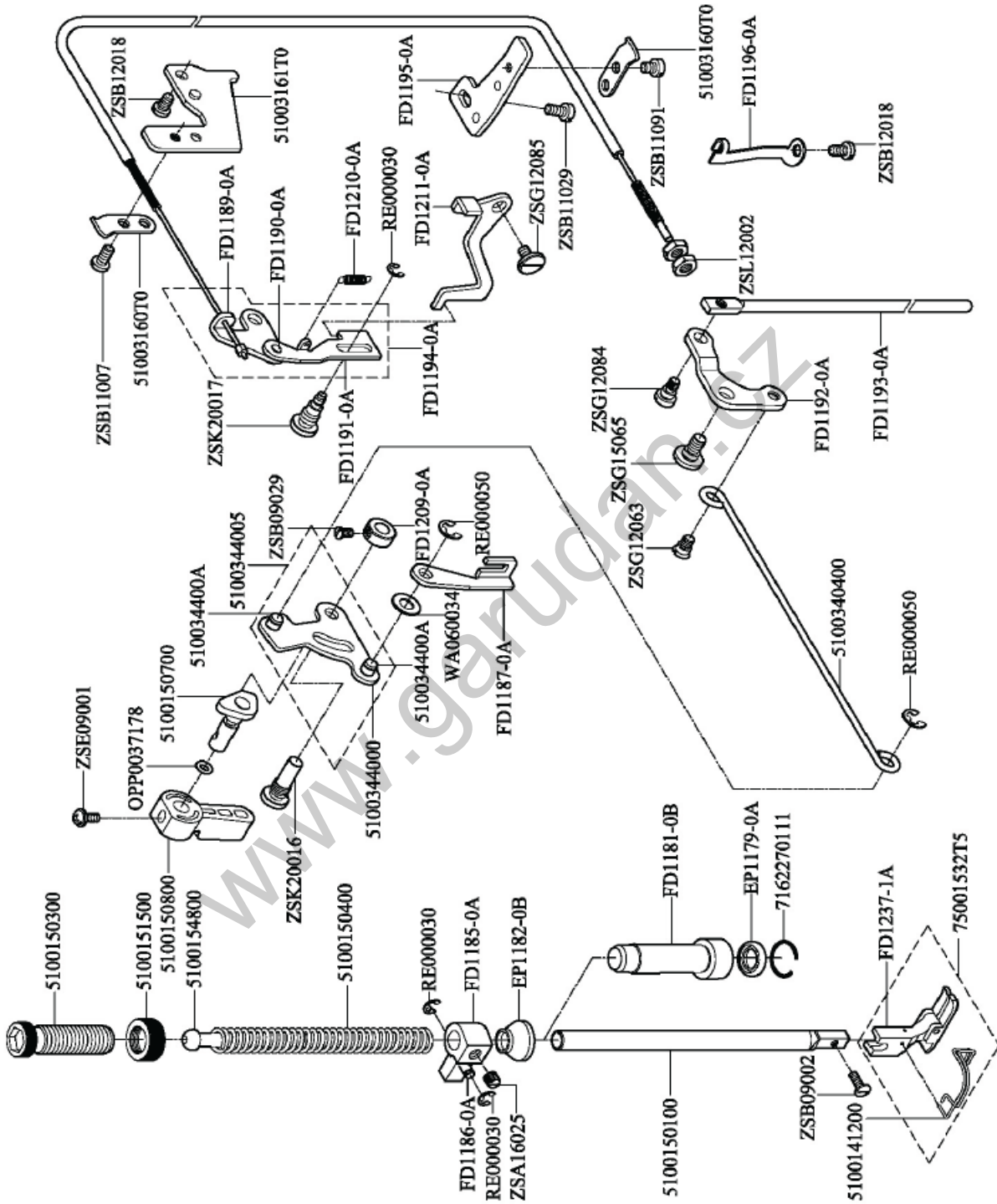

<b>4. PRESSER FOOT MECHANISM (2/2)</b>			
<b>PARTS. NO</b>	<b>NAME OF PARTS</b>	<b>QTY</b>	<b>NOTE</b>
ZSA16025	Screw (1/4-40x6)	1	
ZSB09002	Screw (9/64-40x10)	1	
ZSB09029	Screw (9/64-40x6)	1	
ZSB11007	Screw (11/64-40x7)	1	
ZSB11029	Screw (11/64-40x7)	1	
ZSB11091	Screw (11/64-40x4)	1	
ZSB12018	Screw (3/16-28x6)	2	
ZSE09001	Screw (9/64-40x9.6)	1	
ZSG12063	Screw (3/16-32x4)	1	
ZSG12084	Screw (3/16-32x4.7)	1	
ZSG12085	Screw (3/16-32x4.1)	1	
ZSG15065	Screw (15/64-28x6.5)	1	
ZSK20016	Screw (1/4-40x6)	1	
ZSK20017	Screw (1/4-40x5.5)	1	
ZSL12002	Nut (3/16-32)	2	

5. FEED MECHANISM

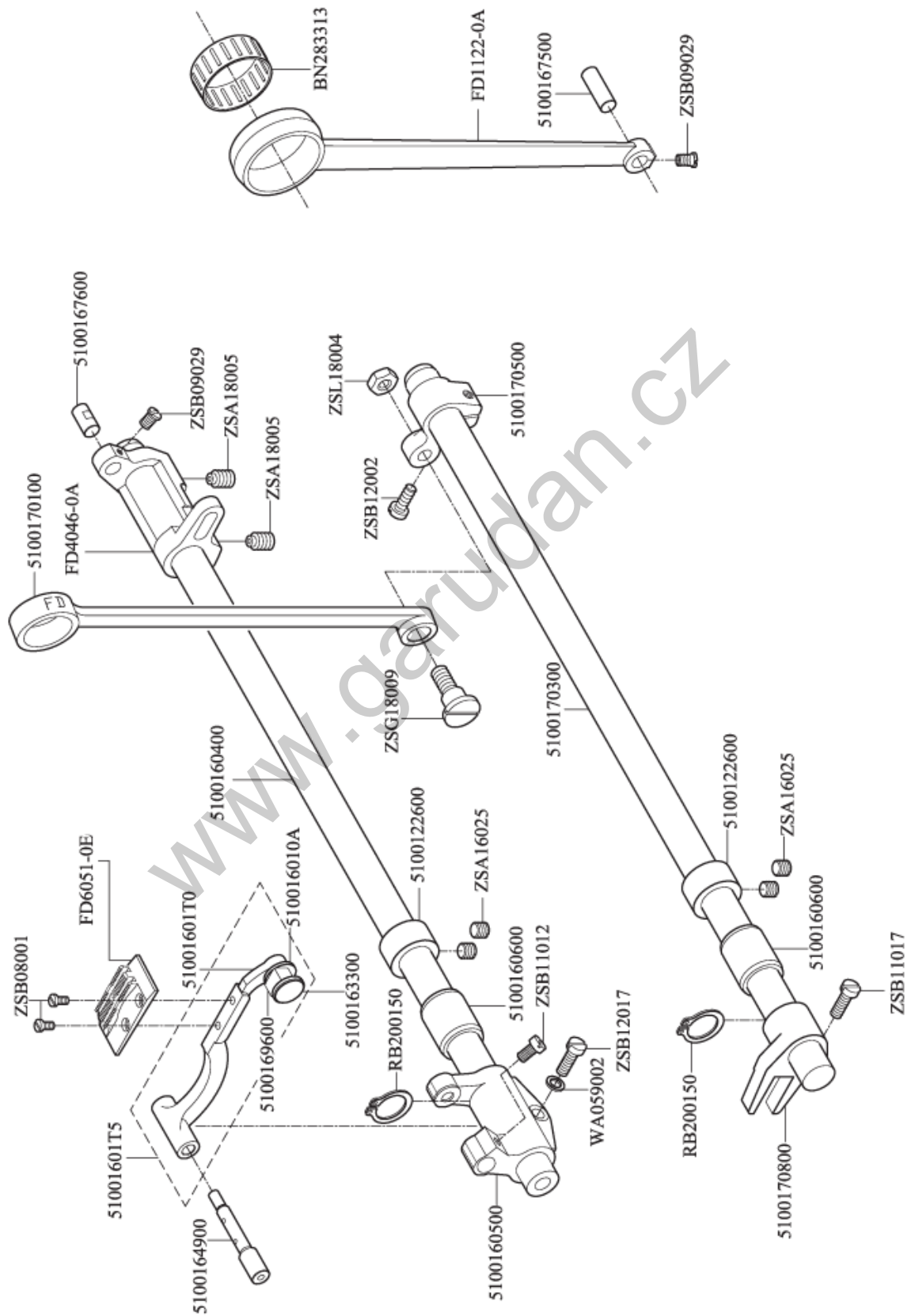

5. FEED MECHANISM			
PARTS. NO	NAME OF PARTS	QTY	NOTE
5100122600	Thrust Collar Asm	2	
5100160400	Feed Rocker Shaft	1	
5100160500	Feed Rocker Asm	1	
5100160600	Shaft Bushing	2	
5100163300	Shaft Bushing	1	
5100164900	Feed Bar Shaft	1	
5100167500	Walking Foot Pin	1	
5100167600	Walking Foot Pin	1	
5100169600	Slide Block	1	
5100170100	Connecting Rod	1	
5100170300	Feed Driving Shaft	1	
5100170500	Feed Arm Compl	1	
5100170800	Driving Shaft Crank Asm	1	
510016010A	Washer	1	
51001601T0	Feed Bar	1	
51001601T5	Feed Base Asm	1	
BN283313	Roller Bearing	1	
FD1122-0A	Rocker Shaft Connecting Rod	1	
FD4046-0A	Feed Rocker Shaft Crank	1	
FD6051-0E	Feed Dog	1	
RB200150	Retaining Ring	2	
WA059002	Washer	1	
ZSA16025	Screw (1/4-40x6)	4	
ZSA18005	Screw (9/32-28x9)	2	
ZSB08001	Screw (1/8-44x6)	2	
ZSB09029	Screw (9/64-40x6)	2	
ZSB11012	Screw (11/64-40x8)	1	
ZSB11017	Screw (11/64-40x12)	1	
ZSB12002	Screw (3/16-28x12)	1	
ZSB12017	Screw (3/16-28x15)	1	
ZSG18009	Screw (9/32-28x12.7)	1	
ZSL18004	Nut (9/32-28)	1	

6. FEED CONTROL MECHANISM

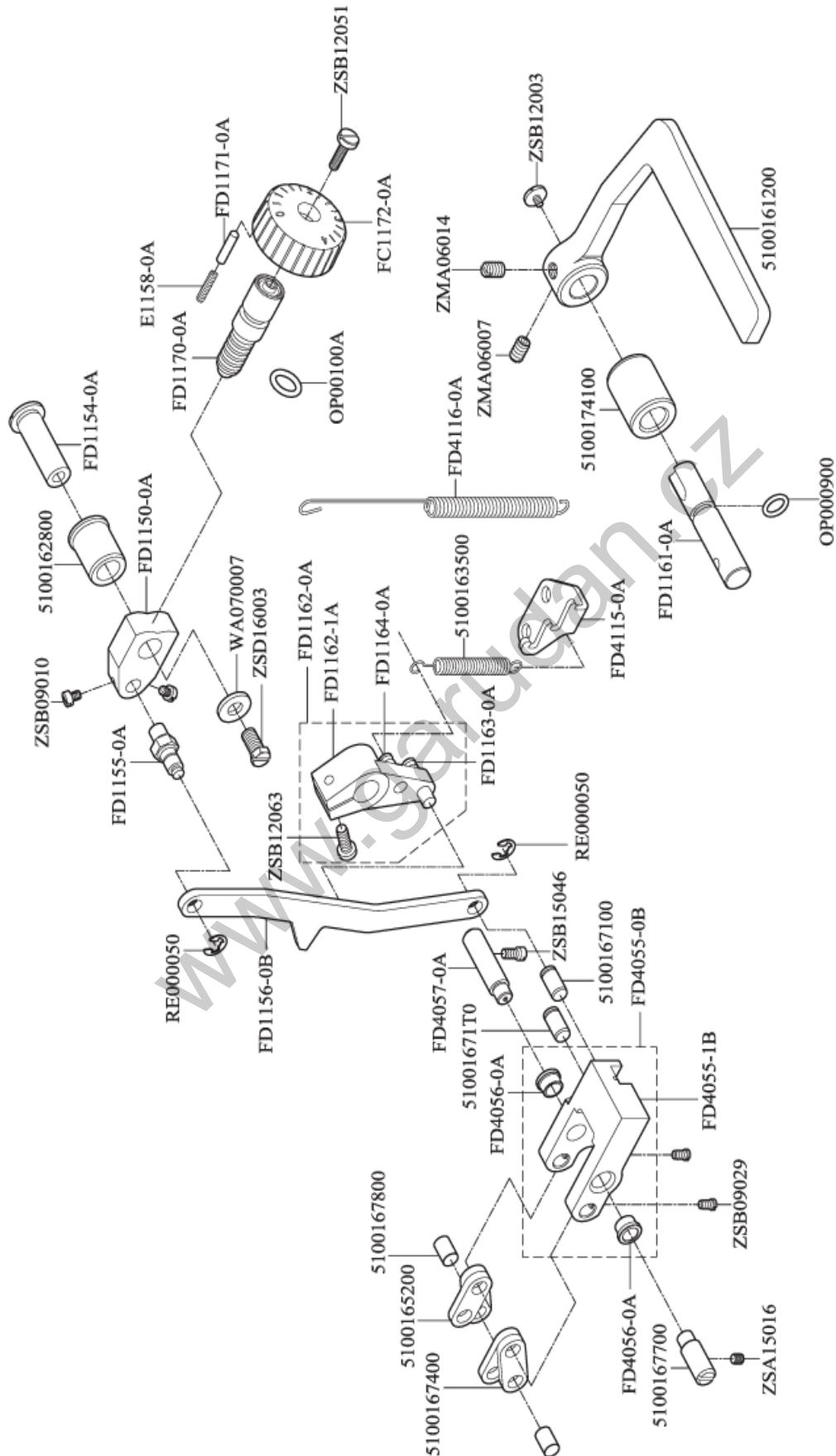



6. FEED CONTROL MECHANISM			
PARTS. NO	NAME OF PARTS	QTY	NOTE
5100161200	Feed Lever Asm	1	
5100162800	Feed Regulator Bushing	1	
5100163500	Spring	1	
5100165200	Connecting Link	2	
5100167100	Pin	1	
5100167400	Connecting Link	2	
5100167700	Adjusting Link Fulcrum Shaft	1	
5100167800	Walking Foot Pin	2	
5100174100	Feed Lever Metal	1	
510016741T0	Pin	1	
E1158-0A	Feed Regulator Pin Spring	1	
FC1172-0A	Feed Dial	1	
FD1150-0A	Feed Regulator Bushing	1	
FD1154-0A	Feed Regulator Shaft	1	
FD1155-0A	Pin	1	
FD1156-0B	Feed Adjust Rod	1	
FD1161-0A	Feed Reverse Shaft	1	
FD1162-0A	Feed Reverse Arm Asm	1	
FD1162-1A	Feed reverse Arm	1	
FD1163-0A	Pin	1	
FD1164-0AS	Pin	1	
FD1170-0A	Feed Regulator Screw	1	
FD1171-0A	Pim	1	
FD4055-0B	Feed Adjust Link Asm	1	
FD4055-1A	Holder	1	
FD4056-0A	Holder	2	
FD4057-0A	Adjusting Link Fulcrum Shaft	1	
FD4115-0A	Feed Spring Hook	1	
FD4116-0A	Spring	1	
OP000900	Rubber Ring	1	
OP00100A	Rubber Ring	1	
RE000050	E-Ring	2	
WA070007	Washer	1	
ZMA06007	Screw (M6-1.0x9.5)	1	
ZMA06014	Screw (M6-1.0x10)	1	
ZSA15016	Screw (15/64-28x7)	1	
ZSB09010	Screw (9/64-40x4.5)	2	
ZSB09029	Screw (9/64-40x6)	2	
ZSB12003	Screw (3/16-32x6.5)	1	
ZSB12051	Screw (3/16-28x18)	1	
ZSB12063	Screw (3/16-28x14)	1	
ZSB15046	Screw (3/16-28x10.3)	1	
ZSD16003	Screw (1/4-40x12)	1	

7. THREAD TRIMMER MECHANISM (1/2)

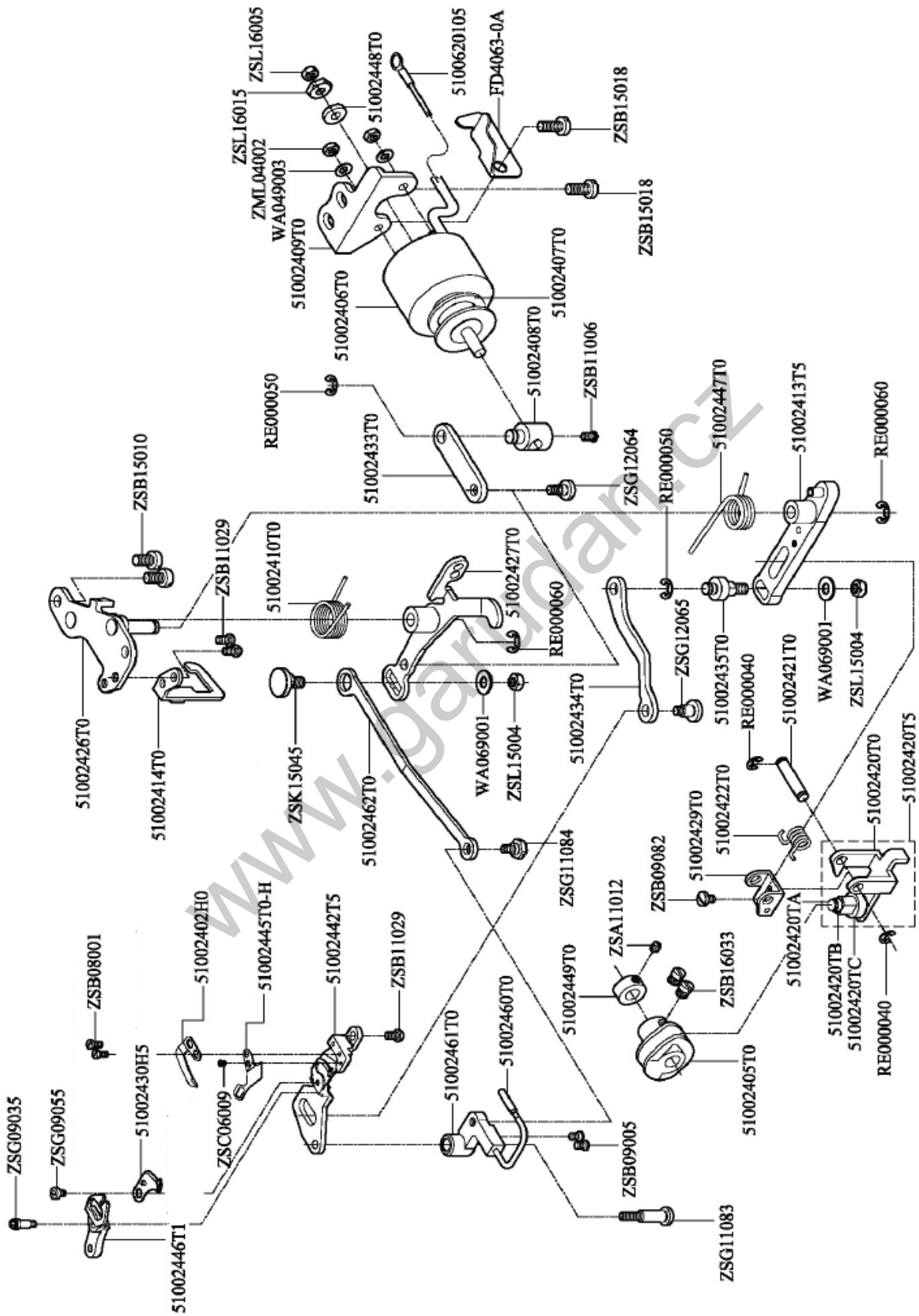

7. THREAD TRIMMER MECHANISM (1/2)			
PARTS. NO	NAME OF PARTS	QTY	NOTE
5100620105	Ground Wire Asm	1	
51002402H0	Counter Knife	1	
51002405T0	Thread Trimmer Cam Asm	1	
51002406T0	Thread Trimmer Solenoid	1	
51002407T0	Solenoid Rubber	1	
51002408T0	Solenoid Pin	1	
51002409T0	Solenoid Base	1	
51002410T0	Spring	1	
51002413T5	Knift Driving Arm Asm	1	
51002414T0	Driving Arm Stopper	1	
51002420T0	Roller Arm	1	
51002420T5	Roller Arm Asm	1	
51002420TA	Roller Shaft	1	
51002420TB	Roller	1	
51002420TC	Bushing	1	
51002421T0	Roller Fulcrum Shaft	1	
51002422T0	Spring	1	
51002426T0	Base Plate Asm	1	
51002427T0	Clutch Plate Asm	1	
51002429T0	Roller Arm Seat	1	
51002430H5	Moving Knife Asm	1	
51002433T0	Link	1	
51002434T0	Link	1	
51002435T0	Moving Knife Link Pin	1	
51002442T5	Knife Mouting Base	1	
51002445T0-H	Thread Guide For Knife	1	
51002446T1	Forked Base For Knife	1	
51002447T0	Spring	1	
51002448T0	Solenoid Rubber	1	
51002449T0	Cam Collar Asm	1	
51002460T0	Hook Thread Presser Asm	1	
51002461T0	Picker Arm	1	
51002462T0	Link	1	
FD4063-0A	Tube Holder Lower	1	
RE000040	E-Ring	2	
RE000050	E-Ring	2	
RE000060	E-Ring	2	
WA049003	Washer	2	
WA069001	Washer	2	

7. THREAD TRIMMER MECHANISM (2/2)

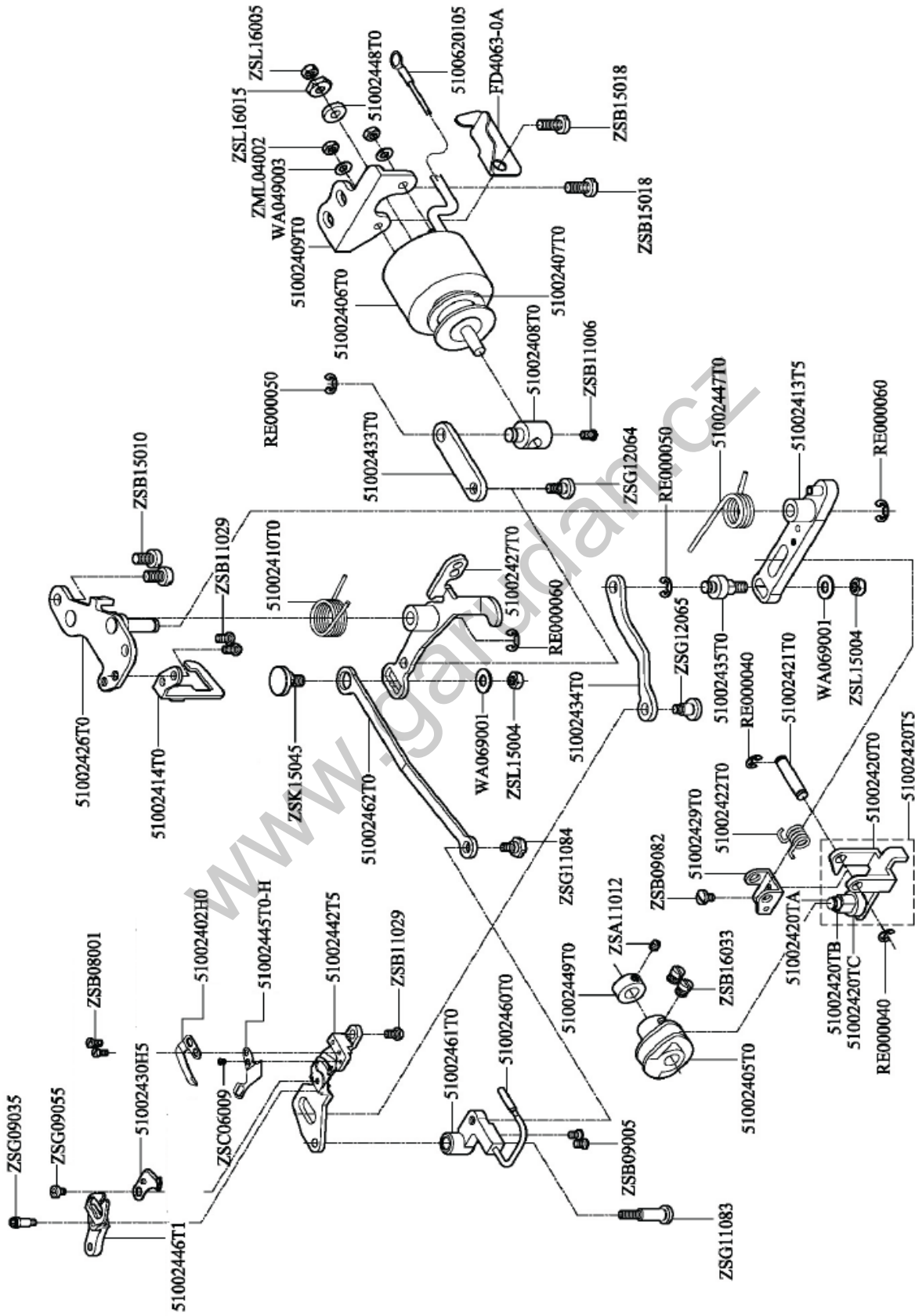

<b>7. THREAD TRIMMER MECHANISM (2/2)</b>			
<b>PARTS. NO</b>	<b>NAME OF PARTS</b>	<b>QTY</b>	<b>NOTE</b>
ZML04002	Nut (M4-0.7)	2	
ZSA11012	Screw (11/64-40x4.6)	1	
ZSB08001	Screw (1/8-44x6)	2	
ZSB09005	Screw (9/64-40x5)	2	
ZSB09082	Screw (9/64-40x6)	1	
ZSB11006	Screw (11/16-40x6.5)	1	
ZSB11029	Screw (11/64-40x7)	3	
ZSB15010	Screw (15/64-28x10)	2	
ZSB15018	Screw (15/64-28x12)	2	
ZSB16033	Screw (1/4-28x4.8)	2	
ZSC06009	Screw (3/32-56x2.3)	1	
ZSG09035	Screw (9/64-40x2.8)	1	
ZSG09055	Screw (9/64-40x3.4)	1	
ZSG11083	Screw (11/64-40x11.8)	1	
ZSG11084	Screw (11/64-40x4.8)	1	
ZSG12064	Screw (3/16-28x6.2)	1	
ZSG12065	Screw (3/16-32x3.2)	1	
ZSK15045	Screw (15/64-28x6.6)	1	
ZSL15004	Nut (15/64-28)	2	
ZSL16005	Nut (1/4-40)	1	
ZSL16015	Nut (1/4-40)	1	

### 8. NEEDLE FEED MECHANISM

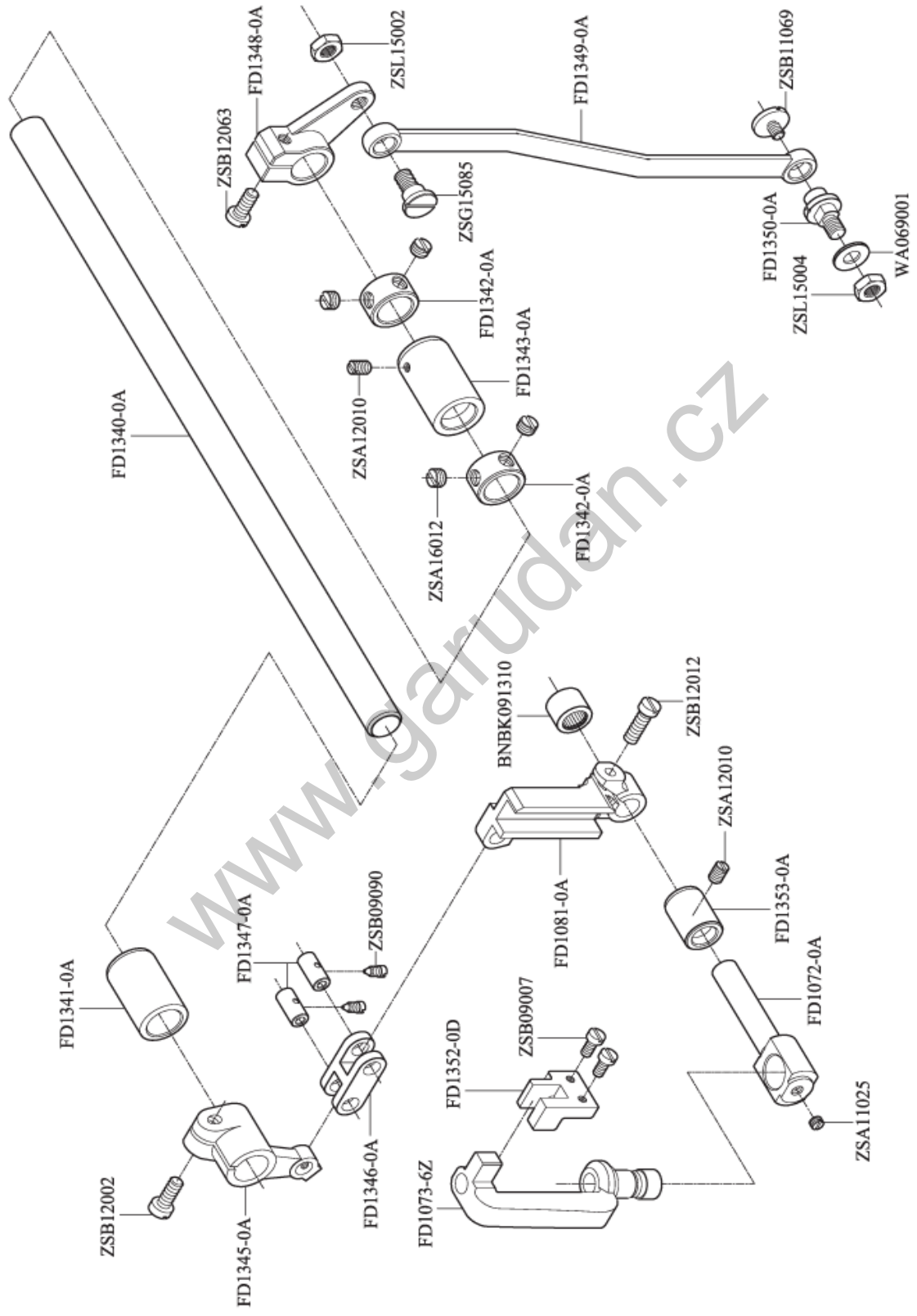

8. NEEDLE FEED MECHANISM			
PARTS. NO	NAME OF PARTS	QTY	NOTE
BNBK091310	Roller Bearing	1	
FD1072-0A	Needle Rod Rocking Base Shaft	1	
FD1073-6Z	Bracket	1	
FD1081-0A	Slide Block Guide	1	
FD1340-0A	Connecting Shaft	1	
FD1341-0A	Rock Shaft Bushing Front	1	
FD1342-0A	Thrust Collar Asm	2	
FD1343-0A	Rock Shaft Bushing Rear	1	
FD1345-0A	Driving Crank Front	1	
FD1346-0A	Driving Link	1	
FD1347-0A	Needle Bar Link Pin	2	
FD1348-0A	Shaft Arm Asm (Rear)	1	
FD1349-0A	Connecting Rod	1	
FD1350-0A	Connecting Rod Shaft	1	
FD1352-0D	Needle Bar Frame Guide	1	
FD1353-0A	Bushing	1	
WA069001	Washer	1	
ZSA11025	Screw (11/64-40x2.7)	1	
ZSA12010	Screw (3/16-28x7)	2	
ZSA16012	Screw (1/4-40x4)	4	
ZSB09007	Screw (9/64-40x7.5)	2	
ZSB09090	Screw (9/64-40x3.8)	2	
ZSB11069	Screw (11/64-40x5)	1	
ZSB12002	Screw (3/16-28x12)	1	
ZSB12012	Screw (3/16-28x15)	1	
ZSB12063	Screw (3/16-28x14)	1	
ZSG15085	Screw (15/64-28x7.5)	1	
ZSL15002	Nut (15/64-28)	1	
ZSL15004	Nut (15/64-28)	1	

### 9. AUTOMATIC REVERSE FEED MECHANISM

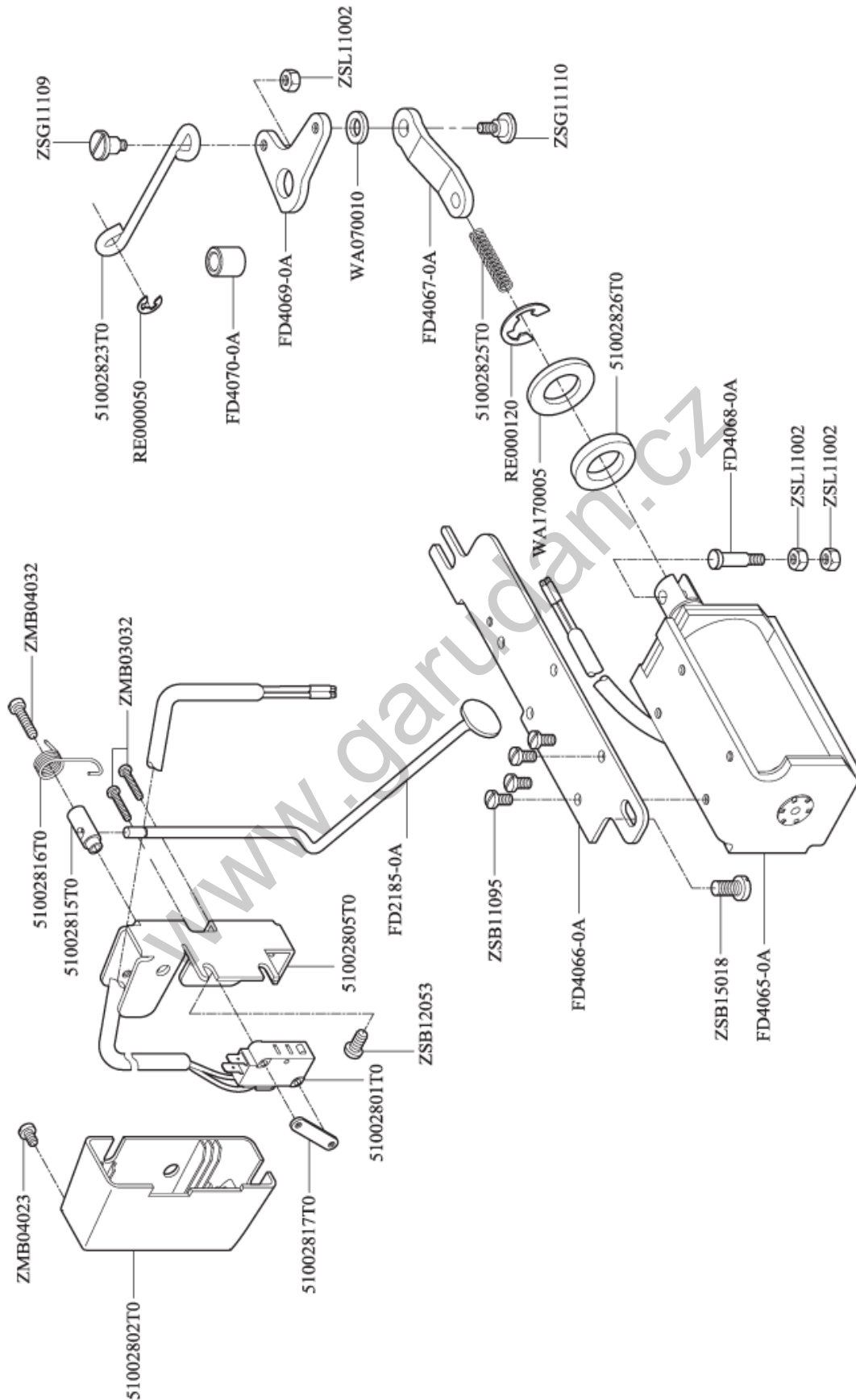



9. AUTOMATIC REVERSE FEED MECHANISM			
PARTS. NO	NAME OF PARTS	QTY	NOTE
51002801T0	Micro switch	1	
51002802T0	Reverse Feed Switch Cover	1	
51002805T0	Reverse Feed Switch Base	1	
51002815T0	Shaft	1	
51002816T0	Spring	1	
51002817T0	Micro switch Plate	1	
51002823T0	Reverse Feed Connecting Shaft	1	
51002825T0	Spring	1	
51002826T0	Rubber Plunger	1	
FD2185-0A	Reverse Feed Control Lever	1	
FD4065-0A	Reverse Feed Solenoid	1	
FD4066-0A	Solenoid Installing Plate	1	
FD4067-0A	Solenoid Connecting Link	1	
FD4068-0A	Screw	1	
FD4069-0A	Reverse Feed Link	1	
FD4070-0A	Reverse Feed Base Collar	1	
RE000050	E-Ring	1	
RE000120	E-Ring	1	
WA070010	Washer	1	
WA170005	Washer	1	
ZMB03032	Screw (M3-0.5x15)	2	
ZMB04023	Screw (M4-0.7x6)	1	
ZMB04032	Screw (M5-0.6x16)	1	
ZSB11095	Screw (11/64-40x8)	4	
ZSB12053	Screw (3/16-28x9)	1	
ZSB15018	Screw (15/64-28x12)	1	
ZSG11009	Screw (11/64-40x3.4.)	1	
ZSG11110	Screw (11/64-40x7)	1	
ZSL11002	Nut (11/64-40)	3	

### 10. WIPER COMPONENTS MECHANISM

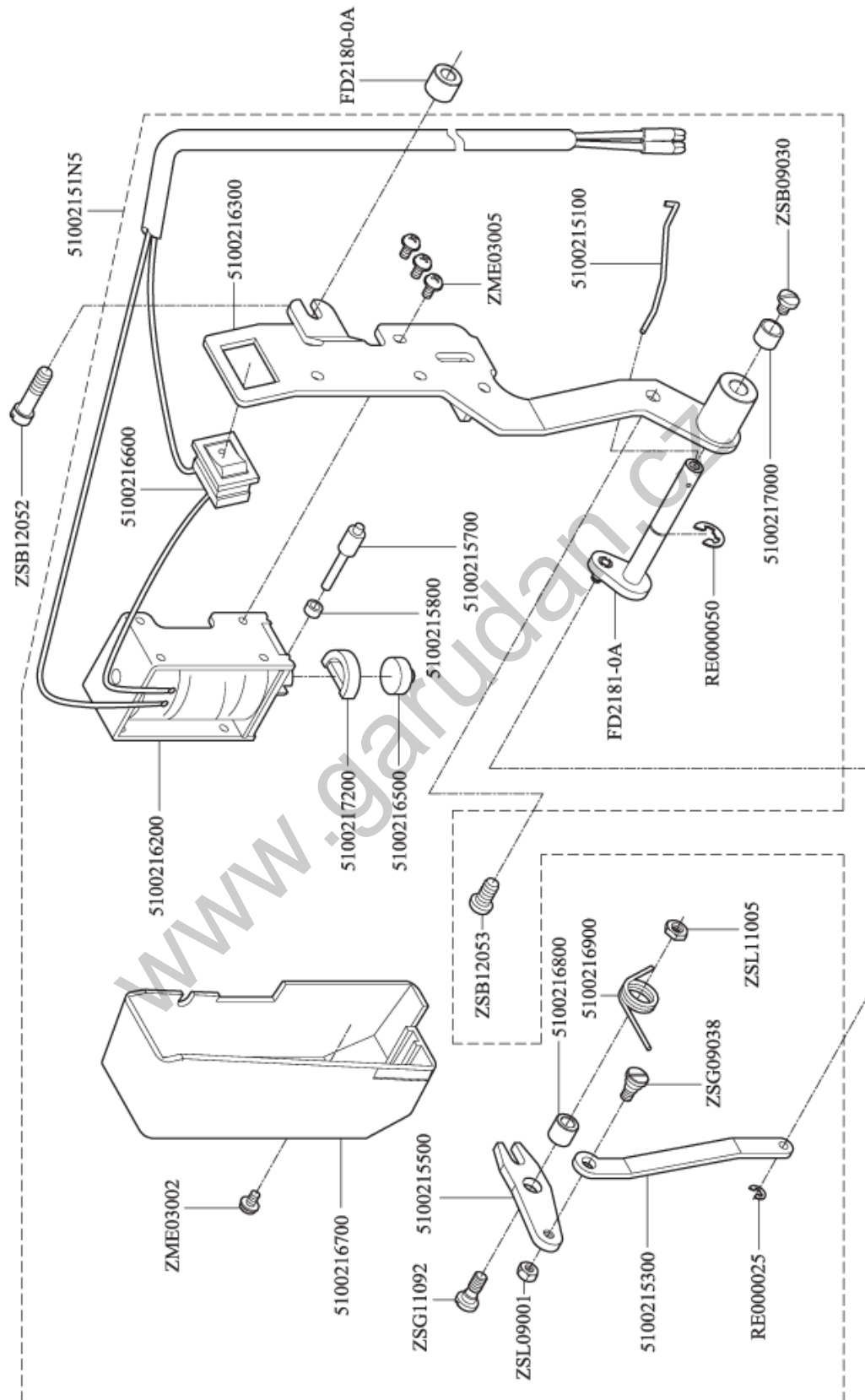

10. WIPER COMPONENTS MECHANISM			
PARTS. NO	NAME OF PARTS	QTY	NOTE
5100215100	Wiper	1	
5100215300	Link	1	
5100215500	Link	1	
5100215700	Pin	1	
5100215800	Wiper Link Collar	1	
5100216200	Wiper Solenoid	1	
5100216300	Wiper Base Asm	1	
5100216500	Wiper Rubber	1	
5100216600	Power Switch	1	
5100216700	Wiper Cover	1	
5100216800	Collar	1	
5100216900	Spring	1	
5100217000	Bracket Installing Collar	1	
5100217200	Wiper Rubber	1	
FD2180-0A	Collar	1	
FD2181-0A	Wiper Driving Shaft Asm	1	
RE000025	E-Ring	1	
RE000050	E-Ring	1	
ZME03002	Screw (M3-0.5x6)	1	
ZME03005	Screw (M3-0.5x7.5)	3	
ZSB09030	Screw (9/64-40x4.6)	1	
ZSB12052	Screw (3/16-28x8)	1	
ZSB12053	Screw (3/16-28x9)	1	
ZSG09038	Screw (9/64-40x5)	1	
ZSG11092	Screw (11/64-40x9)	1	
ZSL09001	Nut (9/64-40)	1	
ZSL11005	Nut (11/64-40)	1	

## 11. OIL LUBRICATION MECHANISM

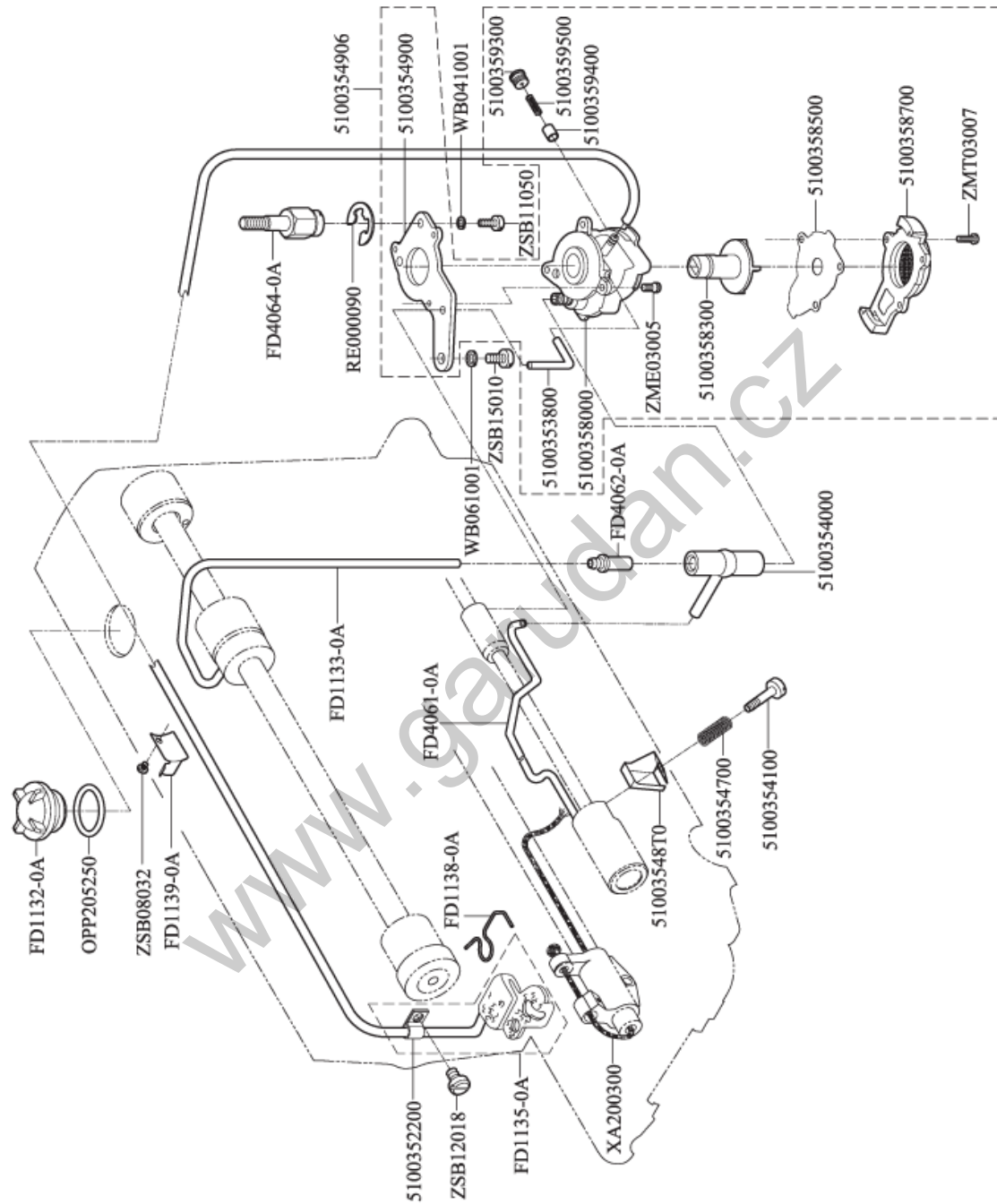

11. OIL LUBRICATION MECHANISM			
PARTS. NO	NAME OF PARTS	QTY	NOTE
5100352200	Holder	1	
5100353800	Hook Driving Shaft Oil Tube	1	
5100354000	Rubber Joint	1	
5100354100	Oil Adjusting Screw	1	
5100354700	Oil Regulator Screw Spring	1	
5100354900	Oil Pump Installing Base	1	
5100358000	Oil Pump	1	
5100358300	Oil Pump Impeller	1	
5100358500	Oil Pump Impeller Cover	1	
5100358700	Lubricating Oil Pump Cover	1	
5100359300	Plunger Screw	1	
5100359400	Plunger	1	
5100359500	Plunger Spring	1	
51003548T0	Holder	1	
FD1132-0A	Oil Sight Window	1	
FD1133-0A	Oil Tube	1	
FD1135-0A	Oil Return Tube Asm	1	
FD1138-0A	Oil Felt Presser	1	
FD1139-0A	Holder	1	
FD4061-0A	Oil Wick Asm	1	
FD4062-0A	Oil Tube Joint	1	
FD4064-0A	Oil Pump Support	1	
OPP205250	Rubber Ring	1	
RE000090	E-Ring	1	
WB041001	Washer	1	
WB061001	Washer	1	
XA200300	Oil Wick	1	
ZME03005	Screw (M3-0.5x7.5)	3	
ZMT03007	Screw (M3-10x10)	3	
ZSB08032	Screw (1/8-44x3)	1	
ZSB11050	screw (11/64-40x10.5)	1	
ZSB12018	Screw (3/16-28x6)	1	
ZSB15010	Screw (15/64-28x10)	1	

## 12. ACCESSORIES (1/3)

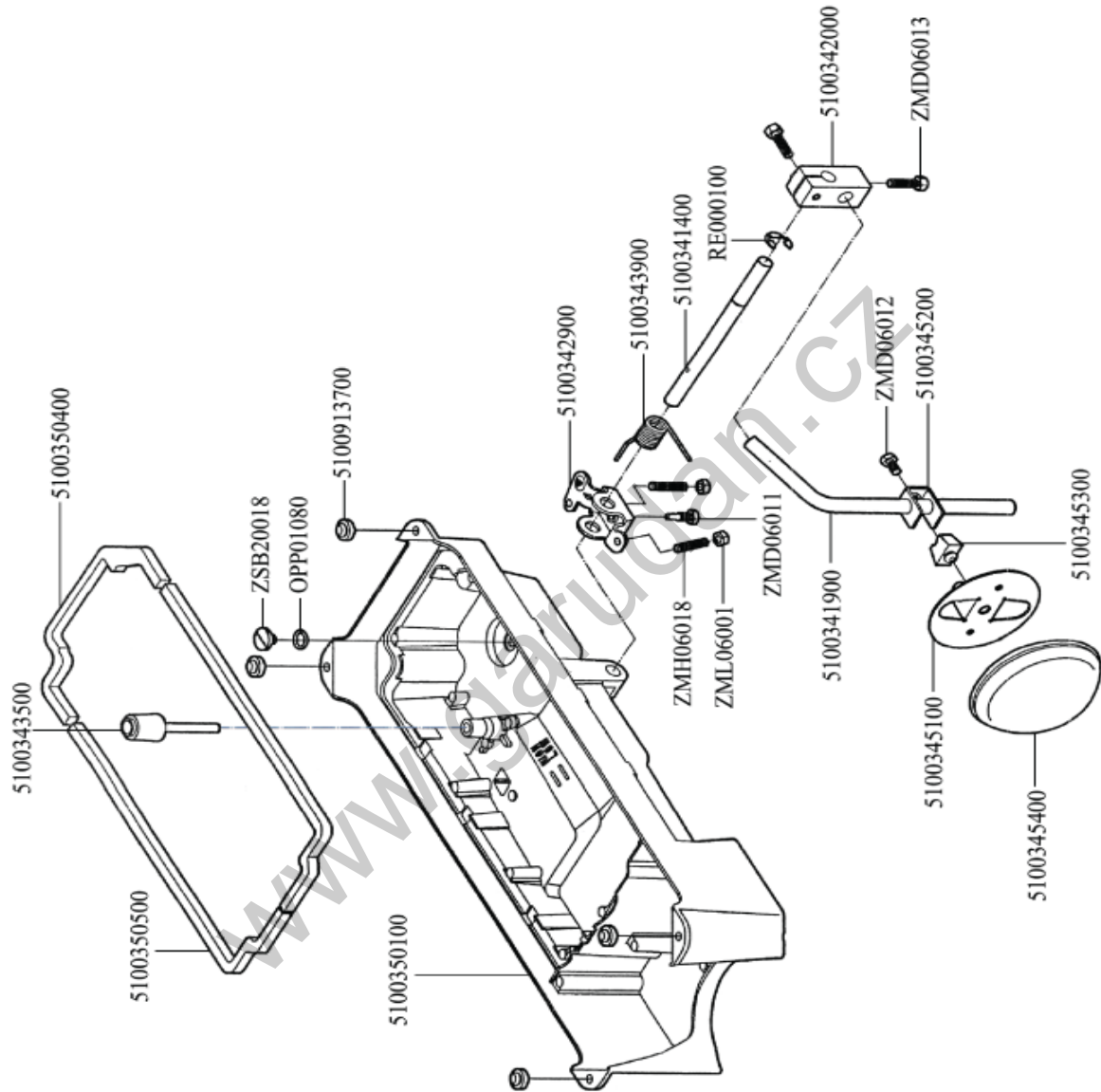

12. ACCESSORIES (1/3)			
PARTS. NO	NAME OF PARTS	QTY	NOTE
5100341400	Knee Press Cross Shaft	1	
5100341900	Knee Lifter Plate Rod	1	
5100342000	Bracket	1	
5100342900	Knee Lifter Rotation Arm	1	
5100343500	Knee Press Lifter Rod	1	
5100343900	Spring	1	
5100345100	Knee Press Plate	1	
5100345200	Knee Press Plate Holder	1	
5100345300	Rubber	1	
5100345400	Knee Press Plate Cover	1	
5100350100	Oil Reservoir	1	
5100350400	Oil Reservoir Rubber Cushion	1	
5100350500	Oil Reservoir Rubber Cushion	2	
5100913700	Rubber Cushion	4	
OPP01080	Rubber Ring	1	
RE000100	E-Ring	1	
ZMD06011	Screw (M6-1.0x10)	1	
ZMD06012	Screw (M6-1.0x11.6)	1	
ZMD06013	Screw (M6-1.0x21)	2	
ZMH06018	Screw (M6-1.0x30)	2	
ZML06001	Nut (M6-1.0)	2	
ZSB20018	Screw (5/16-24x7)	1	

12. ACCESSORIES (2/3)

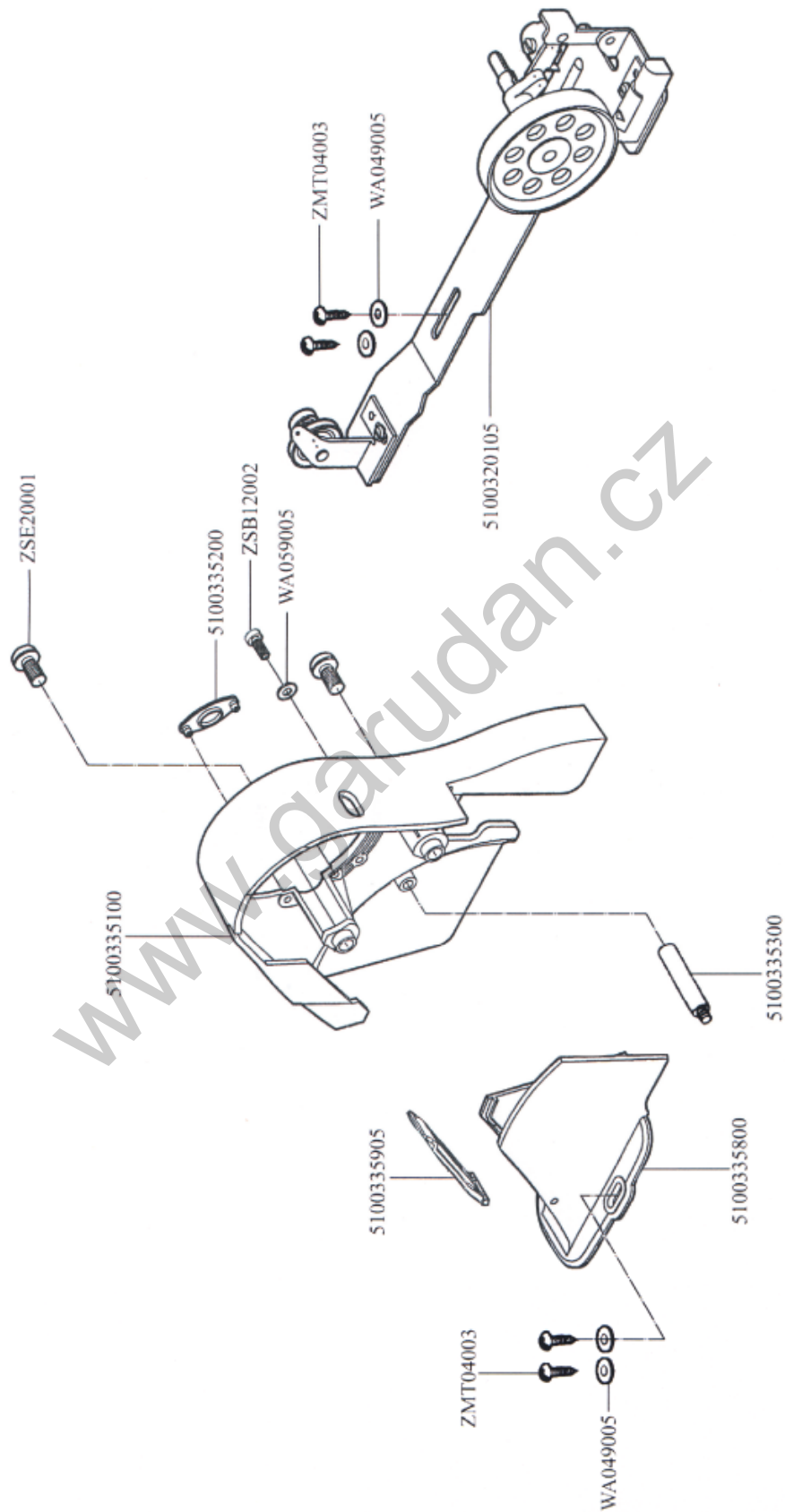



<b>12. ACCESSORIES (2/3)</b>			
<b>PARTS. NO</b>	<b>NAME OF PARTS</b>	<b>QTY</b>	<b>NOTE</b>
5100320105	Bobbin Winder Compl	1	
5100335100	Belt Cover A	1	
5100335200	Belt Cover A Cap	1	
5100335300	Belt Cover Support A	1	
5100335800	Belt Cover B	1	
5100335905	Belt Cover B Cap Asm	1	
WA049005	Washer	4	
WA059005	Washer	1	
ZMT04003	Wood Screw	4	
ZSB12002	Screw (3/16-28x12)	1	
ZSE20001	Screw (5/16-24x15)	2	

12. ACCESSORIES (3/3)

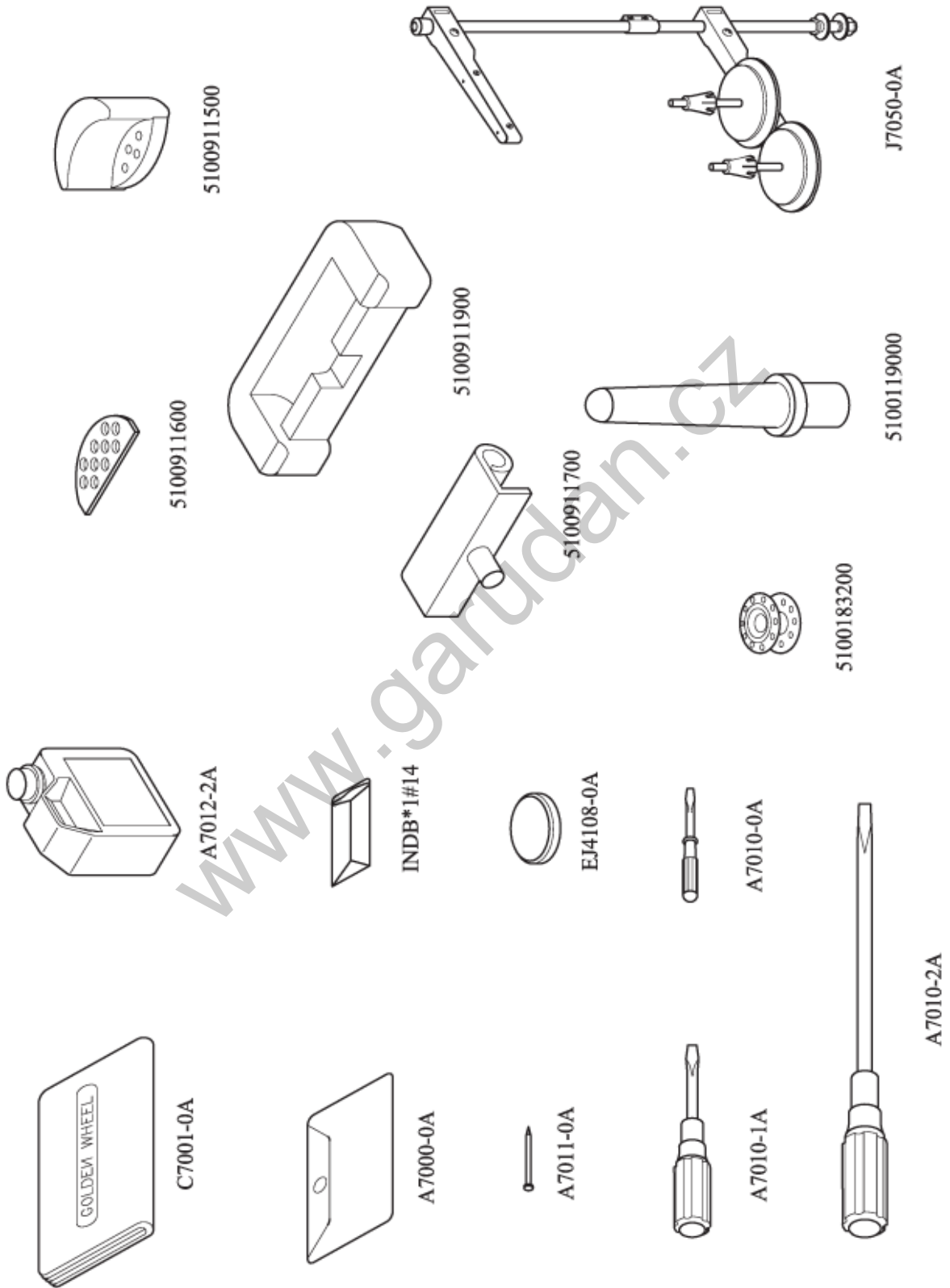

12. ACCESSORIES (3/3)			
PARTS. NO	NAME OF PARTS	QTY	NOTE
5100119000	Support	1	
5100183200	Bobbin	4	
5100911500	Oil Reservoir Rubber Cushion	2	
5100911600	Oil Reservoir Rubber Cushion	2	
5100911700	Button	2	
5100911900	Button Backet	2	
A7000-0A	Accessory Bag	1	
A7010-0A	Screw Driver (Small)	1	
A7010-1A	Screw Driver (Medium)	1	
A7010-2A	Screw Driver (Large)1	1	
A7011-0A	Nail	8	
A7012-2A	Oiler (large)	1	
C7001-0A	Vinyl Cover	1	
EJ4108-0A	Magnet	1	
INDB*1#14	Needle	4	
J7050-0A	Thread Stand	1	